

DEPARTMENT OF ELECTRICAL & ELECTRONICS ENGINEERING

COURSE: POWER SYETMS-II

BRANCH: Electrical and Electronics Engineering

CLASS: III/I Sem.

YEAR: 2020-2021

LECTURE NOTES

UNIT-I

Performance of Short and Medium Length Transmission Lines

SHORT TRANSMISSION LINES

The transmission lines are categorized as three types

- 1) Short transmission line – the line length is up to 80 km
- 2) Medium transmission line – the line length is between 80km to 160 km
- 3) Long transmission line – the line length is more than 160 km



Whatever may be the category of transmission line, the main aim is to transmit power from one end to another. Like other electrical system, the transmission network also will have some power loss and voltage drop during transmitting power from sending end to receiving end. Hence, performance of transmission line can be determined by its efficiency and voltage regulation.

$$\text{Efficiency of transmission line} = \frac{\text{power delivered at receiving end}}{\text{power sent from sending end}} \times 100 \%$$

power sent from sending end – line losses = power delivered at receiving end

Voltage regulation of transmission line is measure of change of receiving end voltage from no-load to full load condition.

$$\% \text{ regulation} = \frac{\text{no load receiving end voltage} - \text{full load receiving end voltage}}{\text{full load voltage}} \times 100 \%$$

Every transmission line will have three basic electrical parameters. The conductors of the line will have resistance, inductance, and capacitance. As the transmission line is a set of conductors being run from one place to another supported by transmission towers, the parameters are distributed uniformly along the line.

The electrical power is transmitted over a transmission line with a speed of light that is 3×10^8 m/sec. Frequency of the power is 50Hz. The wave length of the voltage and current of the power can be determined by the equation given below,

$f\lambda = v$ where f is power frequency, λ is wave length and v is the speed of light.

Therefore, $\lambda = \frac{v}{f}$

$$\lambda = \frac{3 \times 10^8}{50} = 6 \times 10^6 \text{ meters} = 6000 \text{ km.}$$

Hence the wave length of the transmitting power is quite long compared to the generally used line length of transmission line.

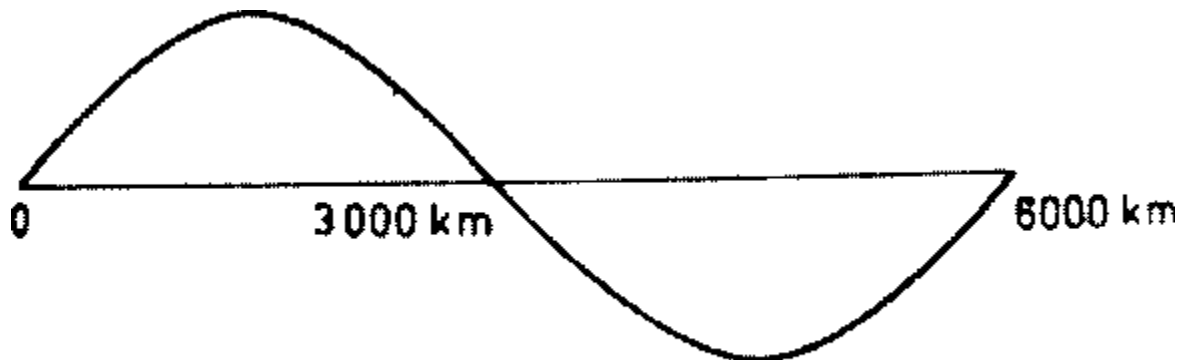

Voltage distribution of 50 Hz supply

For this reason, the transmission line, with length less than 160 km, the parameters are assumed to be lumped and not distributed. Such lines are known as electrically short transmission line. This electrically short transmission lines are again categorized as short transmission line (length up to 80 km) and medium transmission line (length between 80 and 160 km). The capacitive parameter of short transmission line is ignored whereas in case of medium length line the capacitance is assumed to be lumped at the middle of the line or half of the capacitance may be considered to be lumped at each ends of the transmission line. Lines with length more than 160 km, the parameters are considered to be distributed over the line. This is called long transmission line.

ABCD PARAMETERS

A major section of power system engineering deals in the transmission of electrical power from one particular place (eg. Generating station) to another like substations or distribution units with maximum efficiency. So its of substantial importance for power system engineers to be thorough with its mathematical modeling. Thus the entire transmission system can be simplified to a **two port network** for the sake of easier calculations.

The circuit of a 2 port network is shown in the diagram below. As the name suggests, a 2 port network consists of an input port PQ and an output port RS. Each port has 2 terminals to connect itself to the external circuit. Thus it is essentially a 2 port or a 4 terminal circuit, having

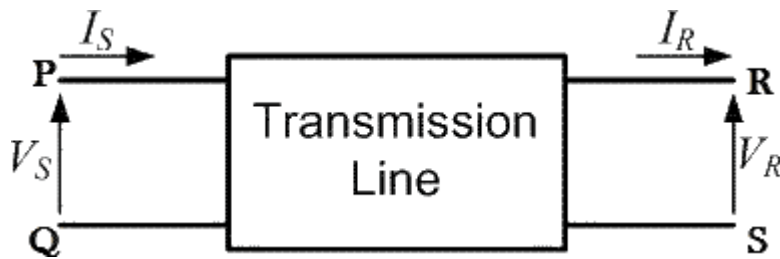

Supply end voltage = V_S

and Supply end current = I_S

Given to the input port P Q.

And there is the Receiving end Voltage = V_R

and Receiving end current = I_R

Given to the output port R S.

As shown in the diagram below.

Now the **ABCD parameters** or the transmission line parameters provide the link between the supply and receiving end voltages and currents, considering the circuit elements to be linear in nature.

Thus the relation between the sending and receiving end specifications are given using **ABCD parameters** by the equations below.

$$V_S = A V_R + B I_R \text{-----(1)}$$

$$I_S = C V_R + D I_R \text{-----(2)}$$

Now in order to determine the ABCD parameters of transmission line let us impose the required circuit conditions in different cases.

ABCD parameters, when receiving end is open circuited

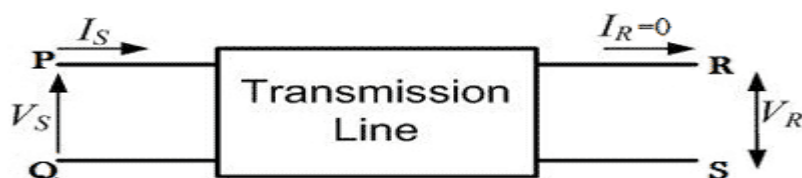

The receiving end is open circuited meaning receiving end current $I_R = 0$.

Applying this condition to equation (1) we get.

$$V_S = A V_R + B \cdot 0 \Rightarrow V_S = A V_R + 0$$

$$A = \left. \frac{V_S}{V_R} \right|_{I_R = 0}$$

Thus it implies that on applying open circuit condition to ABCD parameters, we get parameter A as the ratio of sending end voltage to the open circuit receiving end voltage. Since dimension wise A is a ratio of voltage to voltage, A is a dimensionless parameter.

Applying the same open circuit condition i.e $I_R = 0$ to equation (2)

$$I_S = C V_R + D \cdot 0 \Rightarrow I_S = C V_R + 0$$

$$C = \left. \frac{I_S}{V_R} \right|_{I_R = 0}$$

Thus it implies that on applying open circuit condition to ABCD parameters of transmission line, we get parameter C as the ratio of sending end current to the open circuit receiving end voltage. Since dimension wise C is a ratio of current to voltage, its unit is mho.

Thus C is the open circuit conductance and is given by

$$C = I_S / V_R \text{ mho.}$$

ABCD parameters when receiving end is short circuited

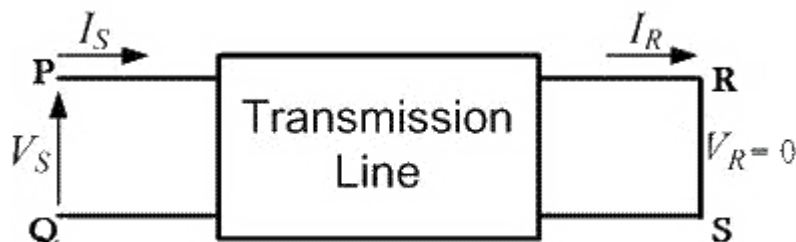

Receiving end is short circuited meaning receiving end voltage $V_R = 0$

Applying this condition to equation (1) we get

$$V_S = A \cdot 0 + B I_R \Rightarrow V_S = 0 + B I_R$$

$$B = \left. \frac{V_S}{I_R} \right|_{V_R = 0}$$

Thus it implies that on applying short circuit condition to ABCD parameters, we get parameter B as the ratio of sending end voltage to the short circuit receiving end current. Since dimension wise B is a ratio of voltage to current, its unit is Ω . Thus B is the short circuit resistance and is

given by

$$B = V_S / I_R \Omega.$$

Applying the same short circuit condition i.e $V_R = 0$ to equation (2) we get

$$I_S = C \cdot 0 + D I_R \Rightarrow I_S = 0 + D I_R$$

$$D = \frac{I_S}{I_R} \Big|_{V_R = 0}$$

Thus it implies that on applying short circuit condition to ABCD parameters, we get parameter D as the ratio of sending end current to the short circuit receiving end current. Since dimension wise D is a ratio of current to current, it's a dimension less parameter. \therefore the ABCD parameters of transmission line can be tabulated as:-

Parameter	Specification	Unit
$A = V_S / V_R$	Voltage ratio	Unit less
$B = V_S / I_R$	Short circuit resistance	Ω
$C = I_S / V_R$	Open circuit conductance	mho
$D = I_S / I_R$	Current ratio	Unit less

SHORT TRANSMISSION LINE

The transmission lines which have length less than 80 km are generally referred as **short transmission lines**.

For short length, the shunt capacitance of this type of line is neglected and other parameters like resistance and inductance of these short lines are lumped, hence the equivalent circuit is represented as given below,

Let's draw the vector diagram for this equivalent circuit, taking receiving end current I_r as reference. The sending end and receiving end voltages make angle with that reference receiving end current, of ϕ_s and ϕ_r , respectively.

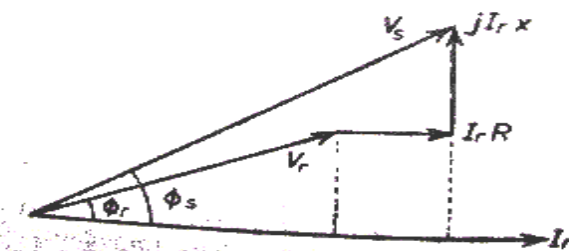
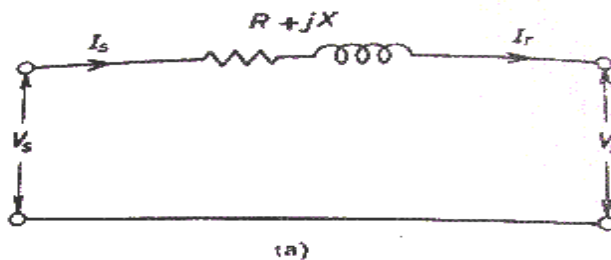

As the shunt capacitance of the line is neglected, hence sending end current and receiving end current is same, i.e.

$$I_s = I_r$$

Now if we observe the vector diagram carefully, we will get,

V_s is approximately equal to

$$V_r + I_r.R.\cos\phi_r + I_r.X.\sin\phi_r$$

That means,

$$V_s \cong V_r + I_r.R.\cos\phi_r + I_r.X.\sin\phi_r \text{ as the it is assumed that } \phi_s \cong \phi_r$$

As there is no capacitance, during no load condition the current through the line is considered as zero, hence at no load condition, receiving end voltage is the same as sending end voltage

As per definition of voltage regulation,

$$\% \text{ regulation} = \frac{V_s - V_r}{V_r} \times 100 \%$$

$$= \frac{I_r.R.\cos\phi_r + I_r.X.\sin\phi_r}{V_r} \times 100 \%$$

$$\text{per unit regulation} = \frac{I_r.R}{V_r} \cos\phi_r + \frac{I_r.X}{V_r} \sin\phi_r = v_r \cos\phi_r + v_x \sin\phi_r$$

Here, v_r and v_x are the per unit resistance and reactance of the short transmission line.

Any electrical network generally has two input terminals and two output terminals. If we consider any complex electrical network in a black box, it will have two input terminals and output terminals. This network is called two – port network. Two port model of a network simplifies the network solving technique. Mathematically a two port network can be solved by 2 by 2 matrixes.

A transmission as it is also an electrical network; line can be represented as two port network.

Hence two port network of transmission line can be represented as 2 by 2 matrixes. Here the concept of ABCD parameters comes. Voltage and currents of the network can be represented as ,

$$V_s = AV_r + BI_r \dots\dots\dots (1)$$

$$I_s = CV_r + DI_r \dots\dots\dots (2)$$

Where A, B, C and D are different constant of the network.

If we put $I_r = 0$ at equation (1), we get

$$A = \left. \frac{V_s}{V_r} \right|_{I_r = 0}$$

Hence, A is the voltage impressed at the sending end per volt at the receiving end when receiving end is open. It is dimension less.

If we put $V_r = 0$ at equation (1), we get

$$B = \left. \frac{V_s}{I_r} \right|_{V_r = 0}$$

That indicates it is impedance of the transmission line when the receiving terminals are short circuited. This parameter is referred as transfer impedance.

$$C = \left. \frac{I_s}{V_r} \right|_{I_r = 0}$$

C is the current in amperes into the sending end per volt on open circuited receiving end. It has the dimension of admittance.

$$D = \left. \frac{I_s}{I_r} \right|_{V_r = 0}$$

D is the current in amperes into the sending end per amp on short circuited receiving end. It is dimensionless.

Now from equivalent circuit, it is found that,

$$V_s = V_r + I_r Z \text{ and } I_s = I_r$$

Comparing these equations with equation 1 and 2 we get,

$A = 1$, $B = Z$, $C = 0$ and $D = 1$. As we know that the constant A, B, C and D are related for passive network as

$$AD - BC = 1.$$

Here, $A = 1$, $B = Z$, $C = 0$ and $D = 1$

$$\Rightarrow 1 \cdot 1 - Z \cdot 0 = 1$$

So the values calculated are correct for short transmission line.

From above equation (1),

$$V_s = AV_r + BI_r$$

When $I_r = 0$ that means receiving end terminals is open circuited and then from the equation 1, we get receiving end voltage at no load

$$V_r' = \frac{V_s}{A}$$

and as per definition of voltage regulation,

$$\% \text{ voltage regulation} = \frac{V_s / A - V_r}{V_r} \times 100 \%$$

Efficiency of Short Transmission Line

The efficiency of short line as simple as efficiency equation of any other electrical equipment, that means

$$\% \text{ efficiency } (\mu) = \frac{\text{Power received at receiving end}}{\text{Power delivered at sending end}} \times 100 \%$$

$$\% \mu = \frac{\text{Power received at receiving end}}{\text{Power received at receiving end} + 3I_r^2 R} \times 100 \%$$

MEDIUM TRANSMISSION LINE

The transmission line having its effective length more than 80 km but less than 250 km, is generally referred to as a **medium transmission line**. Due to the line length being considerably high, admittance Y of the network does play a role in calculating the effective circuit parameters, unlike in the case of short transmission lines. For this reason the modelling of a **medium length transmission line** is done using lumped shunt admittance along with the lumped impedance in series to the circuit.

These lumped parameters of a medium length transmission line can be represented using two different models, namely.

- 1) Nominal Π representation.
- 2) Nominal T representation.

Let's now go into the detailed discussion of these above mentioned models.

Nominal Π representation of a medium transmission line

In case of a nominal Π representation, the lumped series impedance is placed at the middle of the circuit where as the shunt admittances are at the ends. As we can see from the diagram of the Π network below, the total lumped shunt admittance is divided into 2 equal halves, and each half with value $Y/2$ is placed at both the sending and the receiving end while the entire circuit impedance is between the two. The shape of the circuit so formed resembles that of a symbol Π , and for this reason it is known as the nominal Π representation of a medium transmission line. It is mainly used for determining the general circuit parameters and performing load flow analysis.

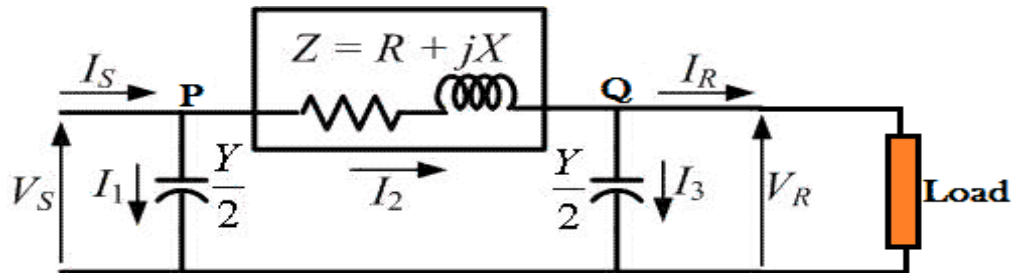

Nominal Π network of medium transmission line.

As we can see here, V_S and V_R is the supply and receiving end voltages respectively, and I_S is the current flowing through the supply end.

I_R is the current flowing through the receiving end of the circuit.

I_1 and I_3 are the values of currents flowing through the admittances. And

I_2 is the current through the impedance Z .

Now applying KCL, at node P, we get.

$$I_S = I_1 + I_2 \text{ -----(1)}$$

Similarly applying KCL, to node Q.

$$I_2 = I_3 + I_R \text{ -----(2)}$$

Now substituting equation (2) to equation (1)

$$I_S = I_1 + I_3 + I_R$$

$$= \frac{Y}{2} V_S + \frac{Y}{2} V_R + I_R \text{ -----(3)}$$

Now by applying KVL to the circuit,

$$V_S = V_R + Z I_2$$

$$= V_R + Z \left(V_R \frac{Y}{2} + I_R \right)$$

$$= \left(Z \frac{Y}{2} + 1 \right) V_R + Z I_R \text{ -----(4)}$$

Now substituting equation (4) to equation (3), we get.

$$\begin{aligned} I_S &= \frac{Y}{2} \left[\left(Z \frac{Y}{2} + 1 \right) V_R + Z I_R \right] + \frac{Y}{2} V_R + I_R \\ &= Y \left(\frac{Y Z}{4} + 1 \right) V_R + \left(\frac{Y Z}{2} + 1 \right) I_R \text{ -----(5)} \end{aligned}$$

Comparing equation (4) and (5) with the standard ABCD parameter equations

$$V_S = A V_R + B I_R$$

$$I_S = C V_R + D I_R$$

We derive the parameters of a medium transmission line as:

$$A = \left(\frac{Y}{2}Z + 1\right)$$

$$B = Z \Omega$$

$$C = Y\left(\frac{Y}{4}Z + 1\right)$$

$$D = \left(\frac{Y}{2}Z + 1\right)$$

Nominal T representation of a medium transmission line

In the **nominal T** model of a medium transmission line the lumped shunt admittance is placed in the middle, while the net series impedance is divided into two equal halves and placed on either side of the shunt admittance. The circuit so formed resembles the symbol of a capital T, and hence is known as the nominal T network of a medium length transmission line and is shown in the diagram below.

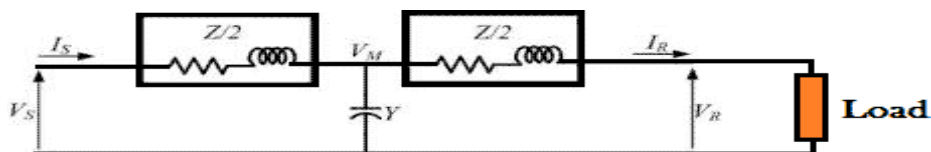

Nominal T representation of a medium transmission line.

Here also V_S and V_R is the supply and receiving end voltages respectively, and I_S is the current flowing through the supply end. I_R is the current flowing through the receiving end of the circuit. Let M be a node at the midpoint of the circuit, and the drop at M, be given by V_m . Applying KVL to the above network we get

$$\frac{V_S - V_M}{Z/2} = Y V_M + \frac{V_M - V_R}{Z/2}$$

$$\text{Or } V_M = \frac{2(V_S + V_R)}{YZ + 4} \text{-----(6)}$$

And the receiving end current

$$\text{Or } I_R = \frac{2(V_M - V_R)}{Z/2} \text{-----(7)}$$

Now substituting V_M from equation (6) to (7) we get,

$$\text{Or } I_R = \frac{[(2V_S + V_R) / YZ + 4] - V_R}{Z/2}$$

Rearranging the above equation:

$$V_S = \left(\frac{Y}{2}Z + 1\right)V_R + Z\left(\frac{Y}{4}Z + 1\right)I_R \text{-----(8)}$$

Now the sending end current is

$$I_S = Y V_M + I_R \text{ -----(9)}$$

Substituting the value of V_M to equation (9) we get,

$$\text{Or } I_S = Y V_R + \left(\frac{Y}{2}Z + 1\right)I_R \text{ -----(10)}$$

Again comparing Comparing equation (8) and (10) with the standard ABCD parameter equations

$$V_S = A V_R + B I_R$$

$$I_S = C V_R + D I_R$$

The parameters of the **T** network of a medium transmission line are

$$A = \left(\frac{Y}{2}Z + 1\right)$$

$$B = Z\left(\frac{Y}{4}Z + 1\right) \Omega$$

$$C = Y \text{ mho}$$

$$D = \left(\frac{Y}{2}Z + 1\right)$$

Performance of Long Transmission Lines

LONG TRANSMISSION LINE

A power transmission line with its effective length of around 250 Kms or above is referred to as a **long transmission line**. Calculations related to circuit parameters (ABCD parameters) of such a power transmission is not that simple, as was the case for a short or medium transmission line. The reason being that, the effective circuit length in this case is much higher than what it was for the former models(long and medium line) and, thus ruling out the approximations considered there like.

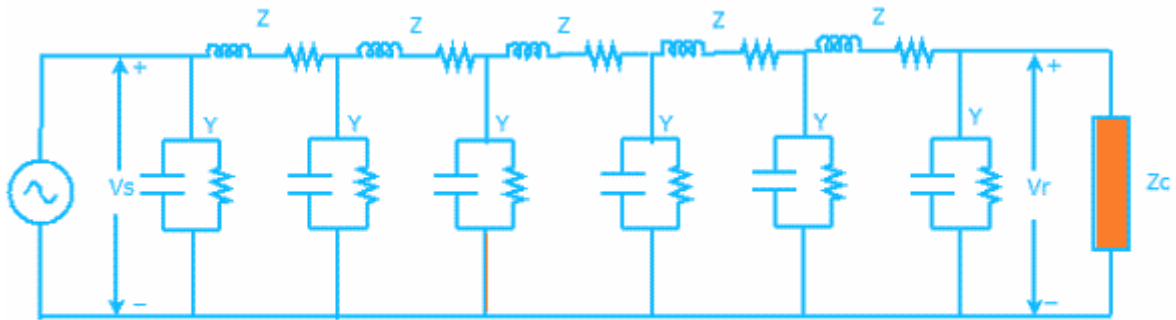

Long Transmission Line model

- a) Ignoring the shunt admittance of the network, like in a small transmission line model.
- b) Considering the circuit impedance and admittance to be lumped and concentrated at a point as was the case for the medium line model.

Rather, for all practical reasons we should consider the circuit impedance and admittance to be distributed over the entire circuit length as shown in the figure below.

The calculations of circuit parameters for this reason is going to be slightly more rigorous as we will see here. For accurate modeling to determine circuit parameters let us consider the circuit of the **long transmission line** as shown in the diagram below.

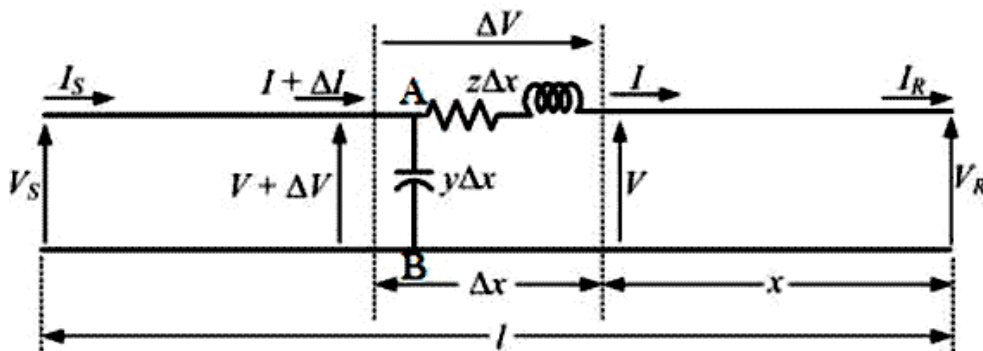

Long Transmission Line.

Here a line of length $l > 250\text{km}$ is supplied with a sending end voltage and current of V_S and I_S respectively, where as the V_R and I_R are the values of voltage and current obtained from the receiving end. Lets us now consider an element of infinitely small length Δx at a distance x from the receiving end as shown in the figure where.

V = value of voltage just before entering the element Δx .

I = value of current just before entering the element Δx .

$V+\Delta V$ = voltage leaving the element Δx .

$I+\Delta I$ = current leaving the element Δx .

ΔV = voltage drop across element Δx .

$z\Delta x$ = series impedance of element Δx

$y\Delta x$ = shunt admittance of element Δx

Where $Z = z l$ and $Y = y l$ are the values of total impedance and admittance of the long transmission line.

\therefore the voltage drop across the infinitely small element Δx is given by

$$\Delta V = I z \Delta x$$

$$\text{Or } I z = \Delta V / \Delta x$$

$$\text{Or } I z = dV / dx \text{ —————(1)}$$

Now to determine the current ΔI , we apply KCL to node A.

$$\Delta I = (V+\Delta V)y\Delta x = V y\Delta x + \Delta V y\Delta x$$

Since the term $\Delta V y\Delta x$ is the product of 2 infinitely small values, we can ignore it for the sake of easier calculation.

$$\therefore \text{ we can write } dI / dx = V y \text{ —————(2)}$$

Now derevating both sides of eq (1) w.r.t x ,

$$d^2 V / d x^2 = z dI / dx$$

Now substituting $dI / dx = V y$ from equation (2)

$$d^2 V / d x^2 = zyV$$

$$\text{or } d^2 V / d x^2 - zyV = 0 \text{ —————(3)}$$

The solution of the above second order differential equation is given by.

$$V = A_1 e^{x\sqrt{yz}} + A_2 e^{-x\sqrt{yz}} \text{ —————(4)}$$

Derivating equation (4) w.r.to x.

$$dV/dx = \sqrt{(yz)} A_1 e^{x\sqrt{yz}} - \sqrt{(yz)} A_2 e^{-x\sqrt{yz}} \text{ —————(5)}$$

Now comparing equation (1) with equation (5)

$$I = \frac{dV}{dx} = \frac{zA_1 e^{x\sqrt{(yz)}}}{\sqrt{(z/y)}} - \frac{zA_2 e^{-x\sqrt{(yz)}}}{\sqrt{(z/y)}} \text{ —————(6)}$$

Now to go further let us define the characteristic impedance Z_c and propagation constant δ of a long transmission line as

$$Z_c = \sqrt{(z/y)} \Omega$$

$$\delta = \sqrt{(yz)}$$

Then the voltage and current equation can be expressed in terms of characteristic impedance and propagation constant as

$$V = A_1 e^{\delta x} + A_2 e^{-\delta x} \text{ —————(7)}$$

$$I = A_1 / Z_c e^{\delta x} + A_2 / Z_c e^{-\delta x} \text{ —————(8)}$$

Now at $x=0$, $V= V_R$ and $I= I_r$. Substituting these conditions to equation (7) and (8) respectively.

$$V_R = A_1 + A_2 \text{ —————(9)}$$

$$I_R = A_1 / Z_c + A_2 / Z_c \text{ —————(10)}$$

Solving equation (9) and (10),

We get values of A_1 and A_2 as,

$$A_1 = (V_R + Z_c I_R) / 2$$

$$\text{And } A_2 = (V_R - Z_c I_R) / 2$$

Now applying another extreme condition at $x=l$, we have $V = V_S$ and $I = I_S$.

Now to determine V_S and I_S we substitute x by l and put the values of A_1 and A_2 in equation (7) and (8) we get

$$V_S = (V_R + Z_C I_R)e^{\delta l/2} + (V_R - Z_C I_R)e^{-\delta l/2} \text{ —————(11)}$$

$$I_S = (V_R/Z_C + I_R)e^{\delta l/2} - (V_R/Z_C - I_R)e^{-\delta l/2} \text{ —————(12)}$$

By trigonometric and exponential operators we know

$$\sinh \delta l = (e^{\delta l} - e^{-\delta l})/2$$

$$\text{And } \cosh \delta l = (e^{\delta l} + e^{-\delta l})/2$$

∴ equation(11) and (12) can be re-written as

$$V_S = V_R \cosh \delta l + Z_C I_R \sinh \delta l$$

$$I_S = (V_R \sinh \delta l)/Z_C + I_R \cosh \delta l$$

Thus comparing with the general circuit parameters equation, we get the ABCD parameters of a long transmission line as,

$$C = \sinh \delta l / Z_C \qquad A = \cosh \delta l \qquad D = \cosh \delta l \qquad B = Z_C \sinh \delta l$$