

Problem-Solving Companion

To accompany

Basic Engineering Circuit Analysis Ninth Edition

J. David Irwin
Auburn University



JOHN WILEY & SONS, INC.

Executive Editor
Assistant Editor
Marketing Manager
Senior Production Editor

Bill Zobrist
Kelly Boyle
Frank Lyman
Jaime Perea

Copyright © 2005, John Wiley & Sons, Inc. All rights reserved

No part of this publication may be reproduced, stored in a retrieval system or transmitted in any form or by any means, electronic, mechanical, photocopying, recording, scanning, or otherwise, except as permitted under Sections 107 or 108 of the 1976 United States Copyright Act, without either the prior written permission of the Publisher, or authorization through payment of the appropriate per-copy fee to the Copyright Clearance Center, 222 Rosewood Drive, Danvers, MA 01923, (508) 750-8400, fax (508) 750-4470. Requests to the Publisher for permission should be addressed to the Permissions Department, John Wiley & Sons, Inc., 605 Third Avenue, New York, NY 10158-0012, (212) 850-6011, fax (212)850-6008, e-mail: PERMREQ@WILEY.COM.

ISBN 0-471-74026-8

TABLE OF CONTENTS

Preface	2
Acknowledgement	2
Chapter 1	
Problems.....	3
Solutions.....	4
Chapter 2	
Problems.....	7
Solutions.....	9
Chapter 3	
Problems.....	18
Solutions.....	19
Chapter 4	
Problems.....	25
Solutions.....	26
Chapter 5	
Problems.....	31
Solutions.....	33
Chapter 6	
Problems.....	42
Solutions.....	44
Chapter 7	
Problems.....	50
Solutions.....	52
Chapter 8	
Problems.....	66
Solutions.....	67
Chapter 9	
Problems.....	73
Solutions.....	74
Chapter 10	
Problems.....	82
Solutions.....	83
Chapter 11	
Problems.....	88
Solutions.....	89
Chapter 12	
Problems.....	94
Solutions.....	96
Chapter 13	
Problems.....	103
Solutions.....	104
Chapter 14	
Problems.....	111
Solutions.....	113
Chapter 15	
Problems.....	127
Solutions.....	129
Chapter 16	
Problems.....	136
Solutions.....	137
Appendix – Techniques for Solving Linear Independent Simultaneous Equations	146

STUDENT PROBLEM COMPANION

To Accompany

BASIC ENGINEERING CIRCUIT ANALYSIS, NINTH EDITION

By

J. David Irwin and R. Mark Nelms

PREFACE

This Student Problem Companion is designed to be used in conjunction with Basic Engineering Circuit Analysis, 8e, authored by J. David Irwin and R. Mark Nelms and published by John Wiley & Sons, Inc.. The material tracts directly the chapters in the book and is organized in the following manner. For each chapter there is a set of problems that are representative of the end-of-chapter problems in the book. Each of the problem sets could be thought of as a mini-quiz on the particular chapter. The student is encouraged to try to work the problems first without any aid. If they are unable to work the problems for any reason, the solutions to each of the problem sets are also included. An analysis of the solution will hopefully clarify any issues that are not well understood. Thus this companion document is prepared as a helpful adjunct to the book.

CHAPTER 1 PROBLEMS

- 1.1 Determine whether the element in Fig. 1.1 is absorbing or supplying power and how much.

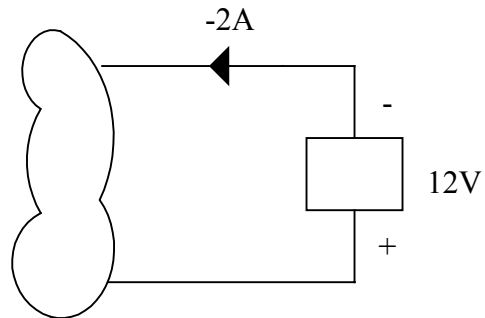

Fig. 1.1

- 1.2 In Fig. 1.2, element 2 absorbs 24W of power. Is element 1 absorbing or supplying power and how much.

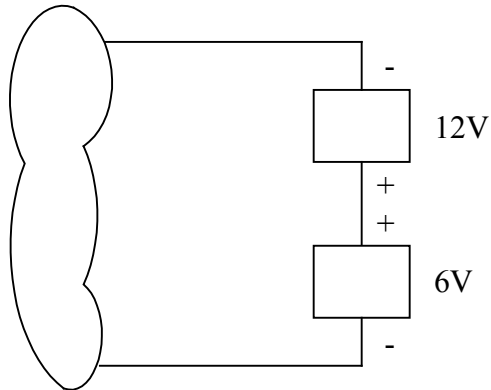

Fig. 1.2

- 1.3 Given the network in Fig.1.3 find the value of the unknown voltage V_X .

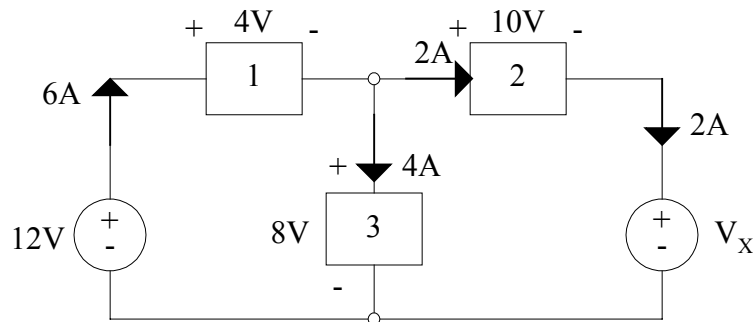

Fig. 1.3

CHAPTER 1 SOLUTIONS

- 1.1 One of the easiest ways to examine this problem is to compare it with the diagram that illustrates the sign convention for power as shown below in Fig. S1.1(b).

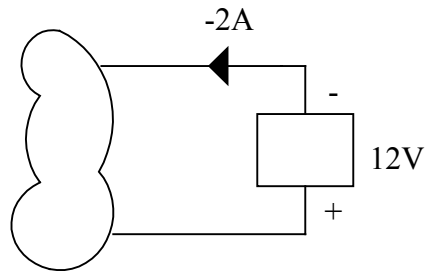

Fig. S1.1(a)

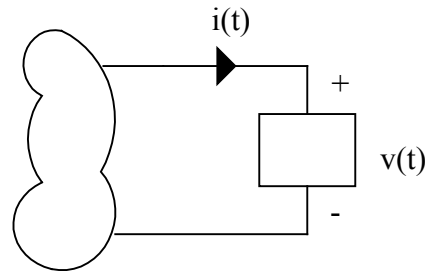

Fig. S1.1(b)

We know that if we simply arrange our variables in the problem to match those in the diagram on the right, then $p(t) = i(t) v(t)$ and the resultant sign will indicate if the element is absorbing (+ sign) or supplying (- sign) power.

If we reverse the direction of the current, we must change the sign and if we reverse the direction of the voltage we must change the sign also. Therefore, if we make the diagram in Fig. S1.1(a) to look like that in Fig. S1.1(b), the resulting diagram is shown in Fig. S1.1(c).

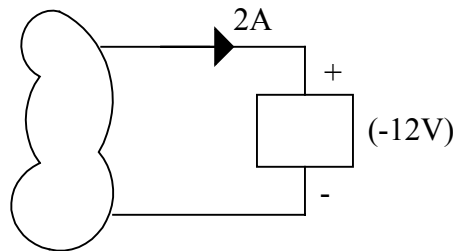

Fig. S1.1(c)

Now the power is calculated as

$$P = (2) (-12) = -24\text{W}$$

And the negative sign indicates that the element is supplying power.

- 1.2 Recall that the diagram for the passive sign convention for power is shown in Fig. S1.2(a) and if $p = vi$ is positive the element is absorbing power and if p is negative, power is being supplied by the element.

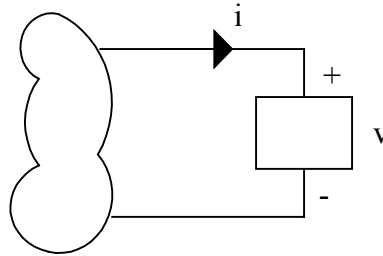

Fig. S1.2(a)

If we now isolate the element 2 and examine it, since it is absorbing power, the current must enter the positive terminal of this element. Then

$$\begin{aligned} P &= VI \\ 24 &= 6(I) \\ I &= 4A \end{aligned}$$

The current entering the positive terminal of element 2 is the same as that leaving the positive terminal of element 1. If we now isolate our discussion on element 1, we find that the voltage across the element is 6V and the current of 4A emanates from the positive terminal. If we reverse the current, and change its sign, so that the isolated element looks like the one in Fig. S1.2(a), then

$$P = (6) (-4) = -24W$$

And element 1 is supplying 24W of power.

- 1.3 By employing the sign convention for power, we can determine whether each element in the diagram is absorbing or supplying power. Then we can apply the principle of the conservation of energy which means that the power supplied must be equal to the power absorbed.

If we now isolate each element and compare it to that shown in Fig. S1.3(a) for the sign convention for power, we can determine if the elements are absorbing or supplying power.

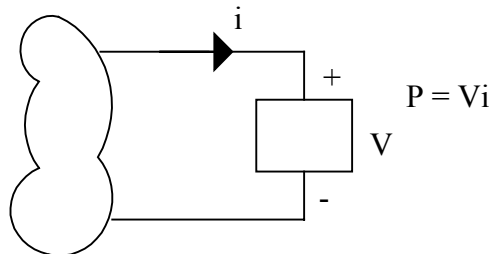

Fig. S1.3(a)

For the 12V source and the current through it to be arranged as shown in Fig. S1.3(a), the current must be reversed and its sign changed. Therefore

$$P_{12V} = (12) (-6) = -72W$$

Treating the remaining elements in a similar manner yields

$$P_1 = (4) (6) = 24W$$

$$P_2 = (2) (10) = 20W$$

$$P_3 = (8) (4) = 32W$$

$$P_{V_X} = (V_X) (2) = 2V_X$$

Applying the principle of the conservation of energy, we obtain

$$-72 + 24 + 20 + 32 + 2V_X = 0$$

And

$$V_X = -2V$$

CHAPTER 2 PROBLEMS

- 2.1 Determine the voltages V_1 and V_2 in the network in Fig. 2.1 using voltage division.

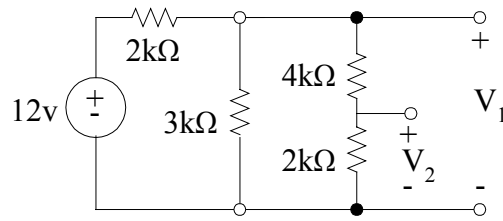

Fig. 2.1

- 2.2 Find the currents I_1 and I_0 in the circuit in Fig. 2.2 using current division.

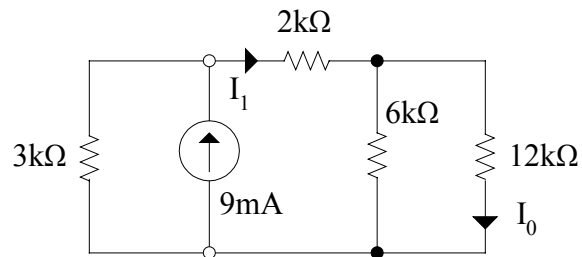

Fig. 2.2

- 2.3 Find the resistance of the network in Fig. 2.3 at the terminals A-B.

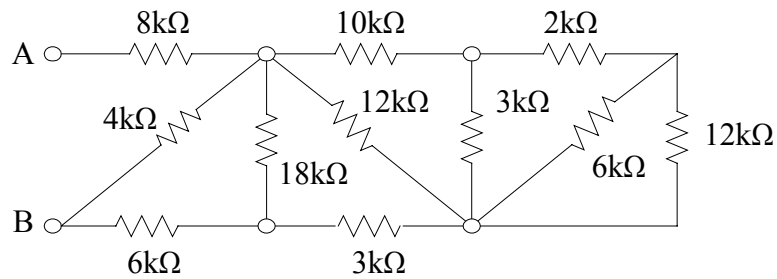

Fig. 2.3

- 2.4 Find the resistance of the network shown in Fig. 2.4 at the terminals A-B.

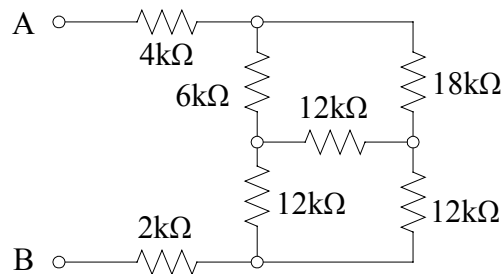

Fig. 2.4

- 2.5 Find all the currents and voltages in the network in Fig. 2.5.

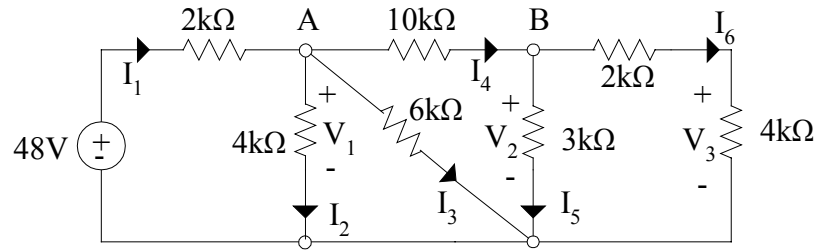

Fig. 2.5

- 2.6 In the network in Fig. 2.6, the current in the $4\text{k}\Omega$ resistor is 3mA . Find the input voltage V_s .

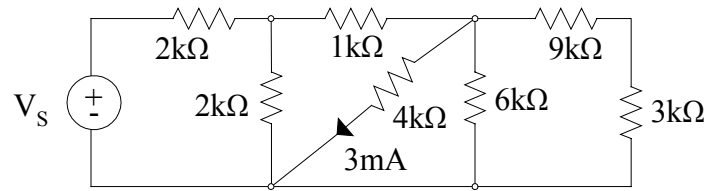

Fig. 2.6

CHAPTER 2 SOLUTIONS

2.1 We recall that if the circuit is of the form

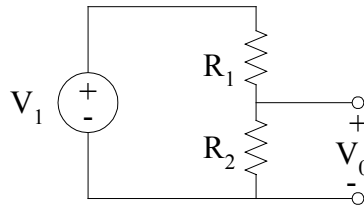

Fig. S2.1(a)

Then using voltage division

$$V_0 = \left(\frac{R_2}{R_1 + R_2} \right) V_1$$

That is the voltage V_1 divides between the two resistors in direct proportion to their resistances. With this in mind, we can draw the original network in the form

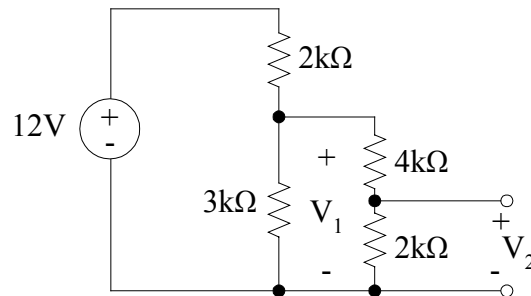

Fig. S2.1(b)

The series combination of the $4\text{k}\Omega$ and $2\text{k}\Omega$ resistors and their parallel combination with the $3\text{k}\Omega$ resistor yields the network in Fig. S2.1(c).

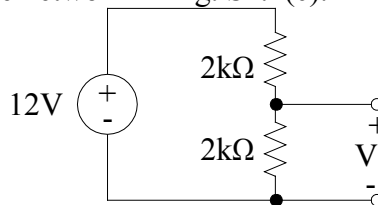

Fig. S2.1(c)

Now voltage division can be sequentially applied. From Fig. S2.1(c).

$$\begin{aligned} V_1 &= \left(\frac{2\text{k}}{2\text{k} + 2\text{k}} \right) 12 \\ &= 6\text{V} \end{aligned}$$

Then from the network in Fig. S2.1(b)

$$V_2 = \left(\frac{2k}{2k + 4k} \right) V_1$$

$$= 2V$$

- 2.2 If we combine the 6k and 12k ohm resistors, the network is reduced to that shown in Fig. S2.2(a).

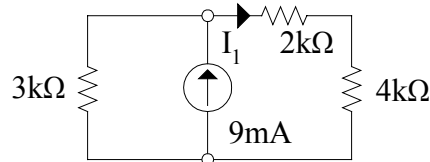

Fig. S2.2(a)

The current emanating from the source will split between the two parallel paths, one of which is the 3kΩ resistor and the other is the series combination of the 2k and 4kΩ resistors. Applying current division

$$I_1 = \frac{9}{k} \left(\frac{3k}{3k + (2k + 4k)} \right)$$

$$= 3\text{mA}$$

Using KCL or current division we can also show that the current in the 3kΩ resistor is 6mA. The original circuit in Fig. S2.2 (b) indicates that I_1 will now be split between the two parallel paths defined by the 6k and 12k-Ω resistors.

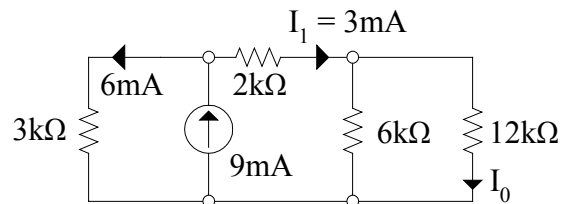

Fig. S2.2(b)

Applying current division again

$$I_0 = I_1 \left(\frac{6k}{6k + 12k} \right)$$

$$I_0 = \frac{3}{k} \left(\frac{6k}{18k} \right)$$

$$= 1\text{mA}$$

Likewise the current in the 6kΩ resistor can be found by KCL or current division to be 2mA. Note that KCL is satisfied at every node.

2.3 To provide some reference points, the circuit is labeled as shown in Fig. S2.3(a).

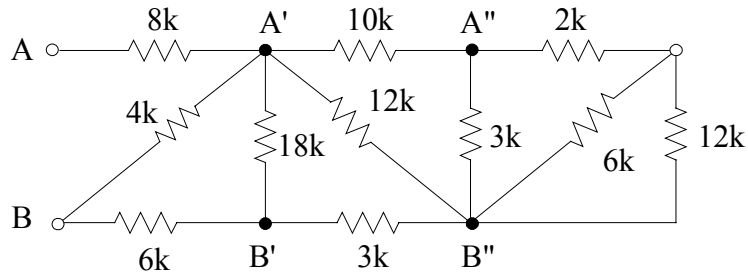

Fig. S2.3(a)

Starting at the opposite end of the network from the terminals A-B, we begin looking for resistors that can be combined, e.g. resistors that are in series or parallel. Note that none of the resistors in the middle of the network can be combined in anyway. However, at the right-hand edge of the network, we see that the 6k and 12k ohm resistors are in parallel and their combination is in series with the 2kΩ resistor. This combination of $6k \parallel 12k + 2k$ is in parallel with the 3kΩ resistor reducing the network to that shown in Fig. S2.3(b).

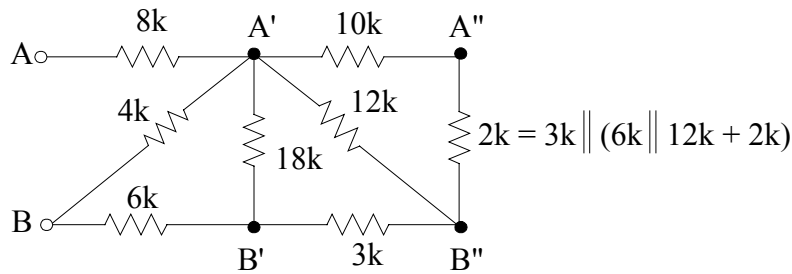

Fig. S2.3(b)

Repeating this process, we see that the 2kΩ resistor is in series with the 10kΩ resistor and that combination is in parallel with the 12kΩ resistor. This equivalent 6kΩ resistor $(2k + 10k) \parallel 12k$ is in series with the 3kΩ resistor and that combination is in parallel with the 18kΩ resistor that $(6k + 3k) \parallel 18k = 6k\Omega$ and thus the network is reduced to that shown in Fig. S2.3(c).

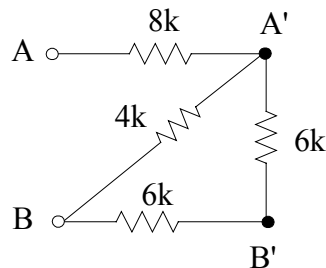

Fig. S2.3(c)

At this point we see that the two $6\text{k}\Omega$ resistors are in series and their combination in parallel with the $4\text{k}\Omega$ resistor. This combination $(6\text{k} + 6\text{k}) \parallel 4\text{k} = 3\text{k}\Omega$ which is in series with $8\text{k}\Omega$ resistors yielding A total resistance $R_{AB} = 3\text{k} + 8\text{k} = 11\text{k}\Omega$.

- 2.4 An examination of the network indicates that there are no series or parallel combinations of resistors in this network. However, if we redraw the network in the form shown in Fig. S2.4(a), we find that the networks have two deltas back to back.

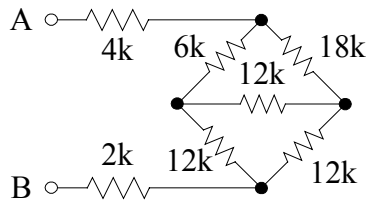

Fig. S2.4(a)

If we apply the $\Delta \rightarrow Y$ transformation to either delta, the network can be reduced to a circuit in which the various resistors are either in series or parallel. Employing the $\Delta \rightarrow Y$ transformation to the upper delta, we find the new elements using the following equations as illustrated in Fig. S2.4(b)

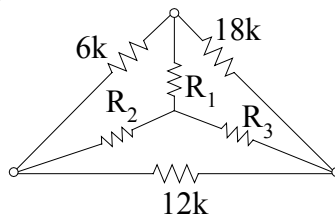

Fig. S2.4(b)

$$R_1 = \frac{(6\text{k})(18\text{k})}{6\text{k} + 12\text{k} + 18\text{k}} = 3\text{k}\Omega$$

$$R_2 = \frac{(6\text{k})(12\text{k})}{6\text{k} + 12\text{k} + 18\text{k}} = 2\text{k}\Omega$$

$$R_3 = \frac{(12\text{k})(18\text{k})}{6\text{k} + 12\text{k} + 18\text{k}} = 6\text{k}\Omega$$

The network is now reduced to that shown in Fig. S2.4(c).

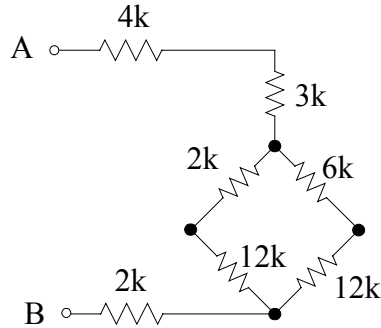

Fig. S2.4(c)

Now the total resistance, R_{AB} is equal to the parallel combination of $(2k + 12k)$ and $(6k + 12k)$ in series with the remaining resistors i.e.

$$\begin{aligned} R_{AB} &= 4k + 3k + (14k \parallel 18k) + 2k \\ &= 16.875k\Omega \end{aligned}$$

If we had applied the $\Delta \rightarrow Y$ transformation to the lower delta, we would obtain the network in Fig. S2.4(d).

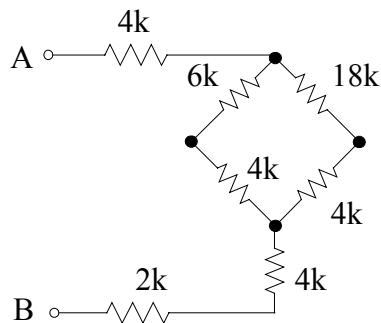

Fig. S2.4(d)

In this case, the total resistance R_{AB} is

$$\begin{aligned} R_{AB} &= 4k + (6k + 4k) \parallel (18k + 4k) + 4k + 2k \\ &= 16.875k\Omega \end{aligned}$$

which is, of course, the same as our earlier result.

- 2.5 Our approach to this problem will be to first find the total resistance seen by the source, use it to find I_1 and then apply Ohm's law, KCL, KVL, current division and voltage division to determine the remaining unknown quantities. Starting at the opposite end of the network from the source, the $2k$ and $4k$ ohm resistors are in series and that combination is in parallel with the $3k\Omega$ resistor yielding the network in Fig. S2.5(a).

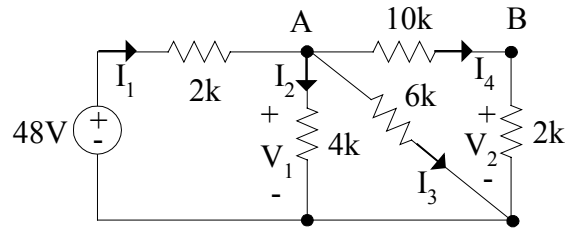

Fig. S2.5(a)

Proceeding, the 2k and 10k ohm resistors are in series and their combination is in parallel with both the 4k and 6k ohm resistors. The combination $(10k + 2k) \parallel 6k \parallel 4k = 2k\Omega$. Therefore, this further reduction of the network is as shown in Fig. S2.5(b).

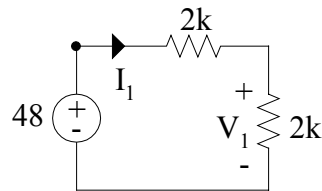

Fig. S2.5(b)

Now I_1 and V_1 can be easily obtained.

$$I_1 = \frac{48}{2k + 2k} = 12\text{mA}$$

And by Ohm's law

$$\begin{aligned} V_1 &= 2kI_1 \\ &= 24\text{V} \end{aligned}$$

or using voltage division

$$\begin{aligned} V_1 &= 48 \left(\frac{2k}{2k + 2k} \right) \\ &= 24\text{V} \end{aligned}$$

once V_1 is known, I_2 and I_3 can be obtained using Ohm's law

$$\begin{aligned} I_2 &= \frac{V_1}{4k} = \frac{24}{4k} = 6\text{mA} \\ I_3 &= \frac{V_1}{6k} = \frac{24}{6k} = 4\text{mA} \end{aligned}$$

I_4 can be obtained using KCL at node A. As shown on the circuit diagram.

$$I_1 = I_2 + I_3 + I_4$$

$$\frac{12}{k} = \frac{6}{k} + \frac{4}{k} + I_4$$

$$I_4 = \frac{2}{k} = 2\text{mA}$$

The voltage V_2 is then

$$V_2 = V_1 - 10kI_4$$

$$= 24 - (10k)\left(\frac{2}{k}\right)$$

$$= 4\text{V}$$

or using voltage division

$$V_2 = V_1 \left(\frac{2k}{10k + 2k} \right)$$

$$= 24 \left(\frac{1}{6} \right)$$

$$= 4\text{V}$$

Knowing V_2 , I_5 can be derived using Ohm's law

$$I_5 = \frac{V_2}{3k}$$

$$= \frac{4}{3}\text{mA}$$

and also

$$I_6 = \frac{V_2}{2k + 4k}$$

$$= \frac{2}{3}\text{mA}$$

current division can also be used to find I_5 and I_6 .

$$I_5 = I_4 \left(\frac{2k + 4k}{2k + 4k + 3k} \right)$$

$$= \frac{4}{3}\text{mA}$$

and

$$I_6 = I_4 \left(\frac{3k}{3k + 2k + 4k} \right)$$

$$= \frac{2}{3} \text{ mA}$$

Finally V_3 can be obtained using KVL or voltage division

$$V_3 = V_2 - 2kI_6$$

$$= 4 - 2k \left(\frac{2}{3k} \right)$$

$$= \frac{8}{3} \text{ V}$$

and

$$V_3 = V_2 \left(\frac{4k}{4k + 2k} \right)$$

$$= \frac{8}{3} \text{ V}$$

2.6 The network is labeled with all currents and voltages in Fig. S2.6.

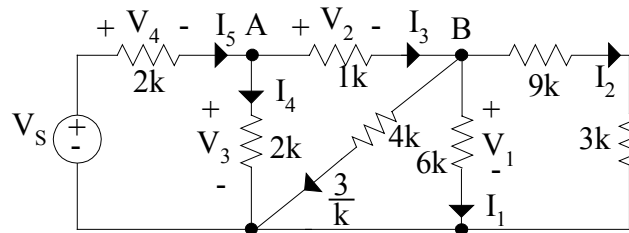

Fig. S2.6

Given the 3mA current in the 4k Ω resistor, the voltage

$$V_1 = \left(\frac{3}{k} \right) (4k) = 12 \text{ V}$$

Now knowing V_1 , I_1 and I_2 can be obtained using Ohm's law as

$$I_1 = \frac{V_1}{6k} = \frac{12}{6k} = 2 \text{ mA}$$

$$I_2 = \frac{V_1}{9k + 3k} = \frac{12}{12k} = 1 \text{ mA}$$

Applying KCL at node B

$$I_3 = \frac{3}{k} + I_1 + I_2$$

$$= 6\text{mA}$$

Then using Ohm's law

$$V_2 = I_3 (1k)$$

$$= 6\text{V}$$

KVL can then be used to obtain V_3 i.e.

$$V_3 = V_2 + V_1$$

$$= 6 + 12$$

$$= 18\text{V}$$

Then

$$I_4 = \frac{V_3}{2k}$$

$$= 9\text{mA}$$

And

$$I_5 = I_3 + I_4$$

$$= \frac{6}{k} + \frac{9}{k}$$

$$= 15\text{mA}$$

using Ohm's law

$$V_4 = (2k) I_5$$

$$= 30\text{V}$$

and finally

$$V_S = V_4 + V_3$$

$$= 48\text{V}$$

CHAPTER 3 PROBLEMS

- 3.1 Use nodal analysis to find V_0 in the circuit in Fig. 3.1.

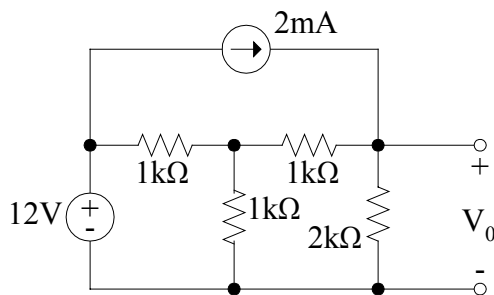

Fig. 3.1

- 3.2 Use loop analysis to solve problem 3.1

- 3.3 Find V_0 in the network in Fig. 3.3 using nodal analysis.

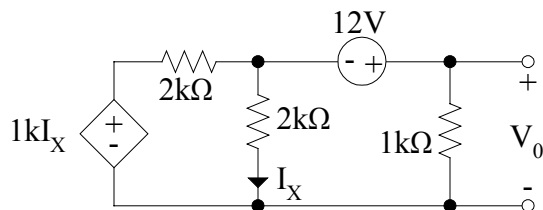

Fig. 3.3

- 3.4 Use loop analysis to find V_0 in the network in Fig. 3.4.

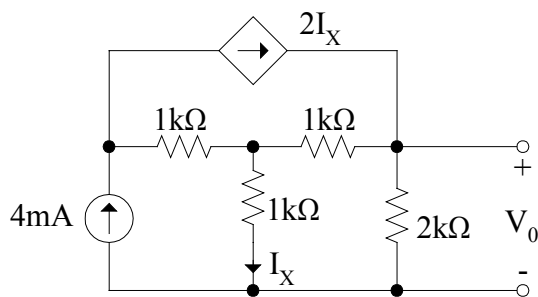

Fig. 3.4

CHAPTER 3 SOLUTIONS

- 3.1 Note that the network has 4 nodes. If we select the node on the bottom to be the reference node and label the 3 remaining non-reference nodes, we obtain the network in Fig. S3.1(a).

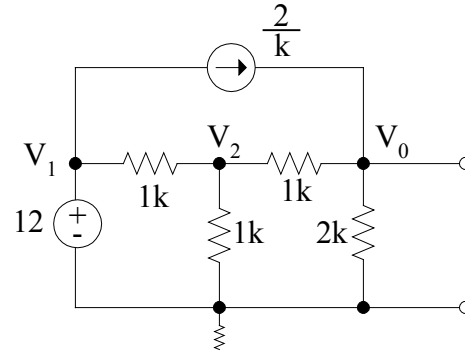

Fig. S3.1(a)

Remember the voltages V_1 , V_2 and V_0 are measured with respect to the reference node. Since the 12V source is connected between node V_1 and the reference, $V_1 = 12V$ regardless of the voltages or currents in the remainder of the circuit. Therefore, one of the 3 linearly independent equations required to solve the network ($N - 1$, where N is the number of nodes) is

$$V_1 = 12$$

The 2 remaining linearly independent equations are obtained by applying KCL at the nodes labeled V_2 and V_0 . Summing all the currents leaving node V_2 and setting them equal to zero yields

$$\frac{V_2 - V_1}{1k} + \frac{V_2}{1k} + \frac{V_2 - V_0}{1k} = 0$$

Similarly, for the node labeled V_0 , we obtain

$$\frac{-2}{k} + \frac{V_0 - V_2}{1k} + \frac{V_0}{2k} = 0$$

The 3 linearly independent equations can be quickly reduced to

$$\begin{aligned} V_2 \left(\frac{3}{k} \right) - V_0 \left(\frac{1}{k} \right) &= \frac{12}{k} \\ -V_2 \left(\frac{1}{k} \right) + V_0 \left(\frac{3}{2k} \right) &= \frac{2}{k} \end{aligned}$$

or

$$3V_2 - V_0 = 12$$

$$-V_2 + \frac{3}{2}V_0 = 2$$

Solving these equations using any convenient method yields $V_2 = \frac{40}{7} \text{ V}$ and $V_0 = \frac{36}{7} \text{ V}$.

We can quickly check the accuracy of our calculations. Fig. S3.1(b) illustrates the circuit and the quantities that are currently known.

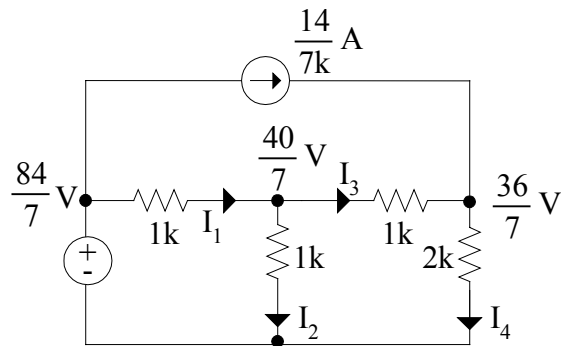

Fig. S3.1(b)

All unknown branch currents can be easily calculated as follows.

$$I_1 = \frac{\frac{84}{7} - \frac{40}{7}}{1\text{k}} = \frac{44}{7\text{k}} \text{ A}$$

$$I_2 = \frac{\frac{40}{7}}{1\text{k}} = \frac{40}{7\text{k}} \text{ A}$$

$$I_3 = \frac{\frac{40}{7} - \frac{36}{7}}{1\text{k}} = \frac{4}{7\text{k}} \text{ A}$$

$$I_4 = \frac{\frac{36}{7}}{2\text{k}} = \frac{18}{7\text{k}} \text{ A}$$

KCL is satisfied at every node and thus we are confident that our calculations are correct.

- 3.2 The network contains 3 “window panes” and therefore 3 linearly independent loop equations will be required to determine the unknown currents and voltages. To begin we arbitrarily assign the loop currents as shown in Fig. S3.2.

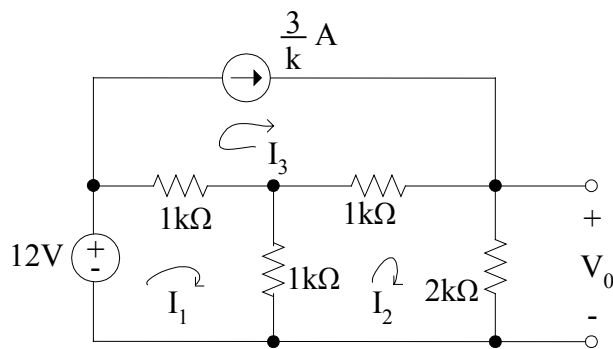

Fig. S3.2

The equations for the loop currents are obtained by employing KVL to the identified loops. For the loops labeled I_1 and I_2 , the KVL equations are

$$-12 + 1k(I_1 - I_3) + 1k(I_1 - I_2) = 0$$

and

$$1k(I_2 - I_1) + 1k(I_2 - I_3) + 2kI_3 = 0$$

In the case of the 3rd loop, the current I_3 goes directly through the current source and therefore

$$I_3 = \frac{2}{k}$$

Combining these equations yields

$$\begin{aligned} 2kI_1 - 1kI_2 &= 14 \\ -1kI_1 + 4kI_2 &= 2 \end{aligned}$$

Solving these equations using any convenient method yields $I_1 = \frac{58}{7k}$ A and $I_2 = \frac{18}{7k}$ A.

Then V_0 is simply

$$\begin{aligned} V_0 &= 2kI_3 \\ &= \frac{36}{7} \text{ V} \end{aligned}$$

Once again, a quick check indicates that KCL is satisfied at every node. Furthermore, KVL is satisfied around every closed path. For example, consider the path around the two “window panes” in the bottom half of the circuit. KVL for this path is

$$-12 + 1k(I_1 - I_3) + 1k(I_2 - I_3) + 2kI_3 = 0$$

$$-12 + 1k\left(\frac{58}{7k} - \frac{14}{7k}\right) + 1k\left(\frac{18}{7k} - \frac{14}{7k}\right) + 2k\left(\frac{18}{7k}\right) = 0$$

$$0 = 0$$

- 3.3 The presence of the two voltage sources indicates that nodal analysis is indeed a viable approach for solving this problem. If we select the bottom node as the reference node, the remaining nodes are labeled as shown in Fig. S3.3(a).

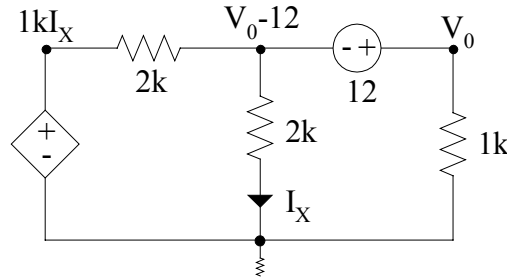

Fig. S3.3(a)

The node at the upper right of the circuit is clearly V_0 , the output voltage, and because the 12V source is tied directly between this node and the one in the center of the network, KVL dictates that the center node must be $V_0 - 12$ e.g. if $V_0 = 14\text{V}$, then the voltage at the center node would be 2V. Finally, the node at the upper left is defined by the dependent source as $1kI_x$.

If we now treat the 12V source and its two connecting nodes as a supernode, the current leaving the supernode to the left is $\frac{V_0 - 12 - 1kI_x}{2k}$, the current down through the center leg of the network is $\frac{V_0 - 12}{2k}$ and the current leaving the supernode on the right edge is $\frac{V_0}{1k}$. Therefore, KCL applied to the supernode yields

$$\frac{V_0 - 12 - 1kI_x}{2k} + \frac{V_0 - 12}{2k} + \frac{V_0}{1k} = 0$$

Furthermore, the control variable I_x is defined as

$$I_x = \frac{V_0 - 12}{2k}$$

combining these two equations yields

$$V_0 = \frac{36}{7}\text{V}$$

The voltages at the remaining non-reference nodes are

$$V_0 - 12 = \frac{36}{7} - 12 = \frac{36}{7} - \frac{84}{7} = \frac{-48}{7} \text{ V}$$

And

$$1\text{k}I_x = 1\text{k}\left(\frac{V_0 - 12}{2\text{k}}\right) = 1\text{k}\left(\frac{-48}{7}\right) = \frac{-24}{7} \text{ V}$$

The network, labeled with the node voltages, is shown in Fig. S3.3(b)

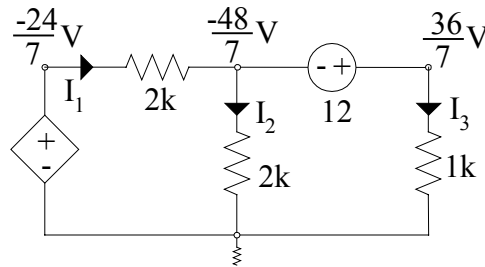

Fig. S3.3(b)

Then

$$I_1 = \frac{\frac{-24}{7} - \left(\frac{-48}{7}\right)}{2\text{k}} = \frac{12}{7\text{k}} \text{ A}$$

$$I_2 = \frac{\frac{-48}{7}}{2\text{k}} = -\frac{24}{7\text{k}} \text{ A}$$

$$I_3 = \frac{\frac{36}{7}}{1\text{k}} = \frac{36}{7\text{k}}$$

Note carefully that KCL is satisfied at every node.

- 3.4 Because of the presence of the two current sources, loop analysis is a viable solution method. We will select our loop currents (we need 3 since there are 3 “window panes” in the network) so that 2 of them go directly through the current sources as shown in Fig. S3.4(a).

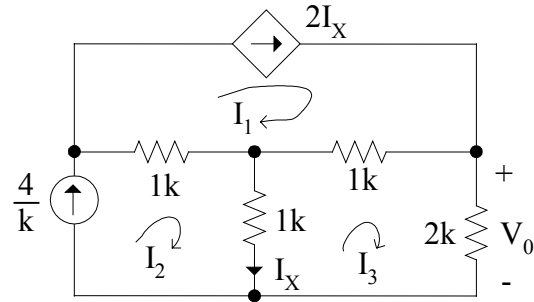

Fig. S3.4(a)

Therefore, two of the three linearly independent equations needed are

$$I_1 = 2I_X = 2(I_2 - I_3)$$

$$I_2 = \frac{4}{k}$$

Applying KVL to the third loop yields

$$1k(I_3 - I_2) + 1k(I_3 - I_1) + 2kI_3 = 0$$

combining equations yields

$$I_3 = 2\text{mA}$$

And then

$$V_0 = 4\text{V}$$

And

$$I_1 = 4\text{mA}$$

Using these values, the branch currents are shown in Fig. S3.4(b)

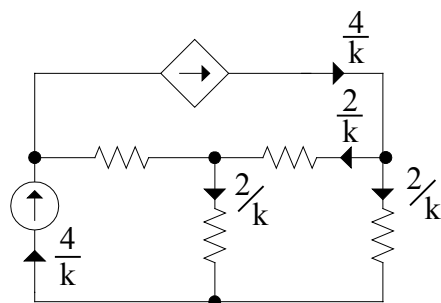

Fig. S3.4(b)

Although one branch of the network are no current, KCL is satisfied at every node.

CHAPTER 4 PROBLEMS

- 4.1 Derive the gain equation for the nonideal noninverting op-amp configuration and show that it reduces to the ideal gain equation if R_i and A are very large, i.e. greater than 10^6 .
- 4.2 Determine the voltage gain of the op-amp circuit shown in Fig. 4.2.

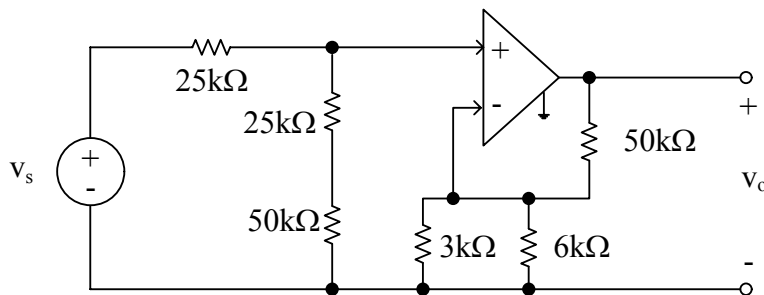

Fig. 4.2

- 4.3 Using the ideal op-amp model show that for the circuit shown in Fig. 4.3, the output voltage is directly related to any small change ΔR .

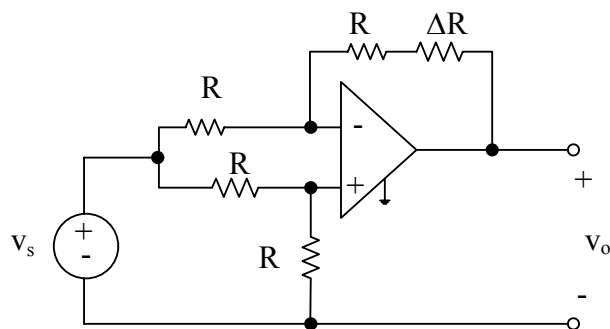

Fig. 4.3

- 4.4 Given an op-amp and seven standard $12\text{k}\Omega$ resistors, design an op-amp circuit that will produce an output of

$$v_o = -2v_1 - \frac{1}{2}v_2$$

CHAPTER 4 SOLUTIONS

4.1 The noninverting op-amp circuit is shown in Fig. S4.1(a).

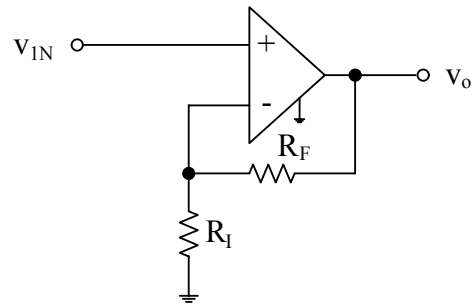

Fig. S4.1(a)

The nonideal model is

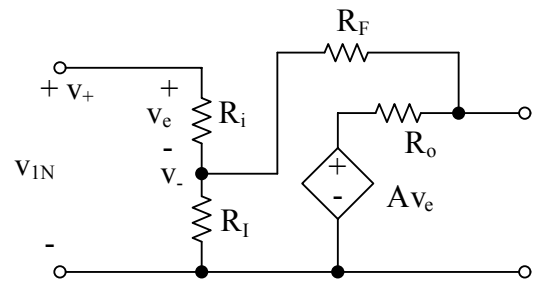

Fig. S4.1(b)

or

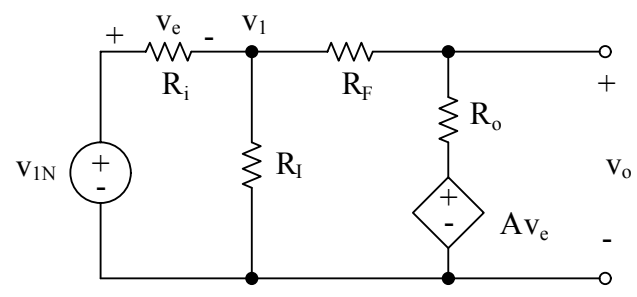

Fig. S4.1(c)

The node equations for this circuit are

$$\frac{v_1 - v_{IN}}{R_i} + \frac{v_1}{R_i} + \frac{v_1 - v_o}{R_F} = 0$$

$$\frac{v_o - v_1}{R_F} + \frac{v_o - Av_e}{R_o} = 0$$

$$v_e = v_{IN} - v_1$$

or

$$\left[\frac{1}{R_i} + \frac{1}{R_I} + \frac{1}{R_F} \right] v_1 - \left[\frac{1}{R_F} \right] v_o = \frac{v_{IN}}{R_i}$$

$$-\left[\frac{1}{R_F} - \frac{A}{R_o} \right] v_1 + \left[\frac{1}{R_F} + \frac{1}{R_o} \right] v_o = \frac{Av_{IN}}{R_o}$$

Following the development on page 141 of the text yields

$$v_o = \frac{\left[\frac{1}{R_F} - \frac{A}{R_o} \right] \frac{v_{IN}}{R_i} + \left[\frac{1}{R_i} + \frac{1}{R_I} + \frac{1}{R_F} \right] \frac{Av_{IN}}{R_o}}{\left(\frac{1}{R_i} + \frac{1}{R_I} + \frac{1}{R_F} \right) \left(\frac{1}{R_F} + \frac{1}{R_o} \right) - \frac{1}{R_F} \left(\frac{1}{R_F} - \frac{A}{R_o} \right)}$$

assuming $R_i \rightarrow \infty$, the equation reduces to

$$\frac{v_o}{v_{IN}} = \frac{\left(\frac{1}{R_I} + \frac{1}{R_F} \right) \left(\frac{A}{R_o} \right)}{\left(\frac{1}{R_I} + \frac{1}{R_F} \right) \left(\frac{1}{R_F} + \frac{1}{R_o} \right) - \frac{1}{R_F} \left(\frac{1}{R_F} - \frac{A}{R_o} \right)}$$

Now dividing both numerator and denominator by A and using $A \rightarrow \infty$ yields

$$\frac{v_o}{v_{IN}} = \frac{\frac{1}{R_o} \left(\frac{1}{R_I} + \frac{1}{R_F} \right)}{\left(\frac{1}{R_o} \right) \left(\frac{1}{R_F} \right)}$$

$$= 1 + \frac{R_F}{R_I}$$

which is the ideal gain equation.

- 4.2 The network in Fig. 4.2 can be reduced to that shown in Fig. S4.2(a) by combining resistors.

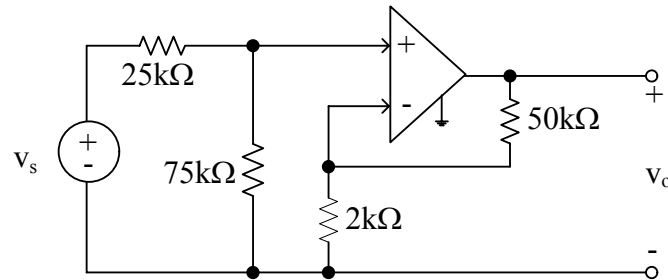

Fig. S4.2(a)

v_+ is determined by the voltage divider at the input, i.e.

$$v_+ = v_s \left[\frac{75\text{k}}{25\text{k} + 75\text{k}} \right] = \frac{3}{4} v_s$$

The op-amp is in a standard noninverting configuration and the gain is $1 + \frac{50\text{k}}{2\text{k}} = 26$.

Therefore

$$v_o = (26) \left(\frac{3}{4} v_s \right)$$

and

$$\frac{v_o}{v_s} = 19.5$$

- 4.3 The node equations for the circuit in Fig. 4.3 are

$$\frac{v_s - v_-}{R} + \frac{v_o - v_-}{R + \Delta R} = 0$$

$$\frac{v_s - v_+}{R} = \frac{v_+}{R}$$

$$v_- = v_+$$

Then

$$v_- = v_+ = \frac{v_s}{2}$$

$$\frac{v_s - \frac{1}{2}v_s}{R} + \frac{v_o - \frac{1}{2}v_s}{R + \Delta R} = 0$$

$$\frac{v_s}{2R} + \frac{v_o}{R + \Delta R} - \frac{v_s}{2(R + \Delta R)} = 0$$

$$\begin{aligned} \frac{v_o}{R + \Delta R} &= v_s \left[\frac{1}{2(R + \Delta R)} - \frac{1}{2R} \right] \\ &= v_s \left[\frac{-\Delta R}{(2R)(R + \Delta R)} \right] \end{aligned}$$

$$v_o = v_s \left[\frac{-\Delta R}{2R} \right]$$

$$\frac{v_o}{v_s} = \frac{-\Delta R}{2R}$$

- 4.4 A weighted-summer circuit shown in Fig. S4.4(a) can be used to produce an output of the form $v_o = -\frac{R}{R_1}v_1 - \frac{R}{R_2}v_2$.

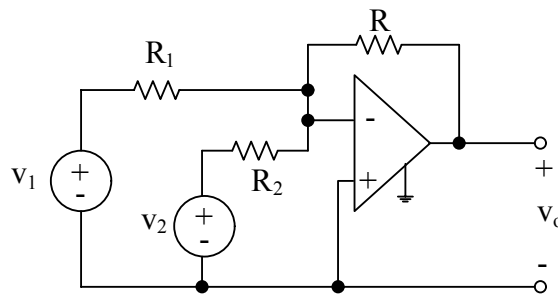

Fig. S4.4(a)

Note that

$$\frac{R}{R_1} = 2 \quad \text{and} \quad \frac{R}{R_2} = \frac{1}{2}$$

Therefore if

$R = 24\text{k}\Omega$ (two $12\text{k}\Omega$ resistors in series)

$R_1 = 12\text{k}\Omega$

$R_2 = 48\text{k}\Omega$ (four $12\text{k}\Omega$ resistors in series)

then the design conditions are satisfied.

CHAPTER 5 PROBLEMS

- 5.1 Find V_0 in the circuit in Fig. 5.1 using the Principle of Superposition.

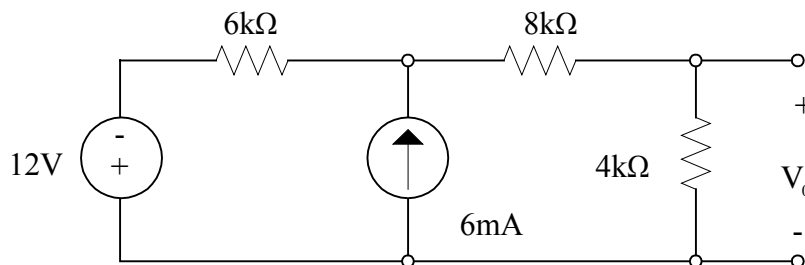

Fig. 5.1

- 5.2 Solve problem 5.1 using source transformation.
- 5.3 Find V_0 in the network in Fig. 5.3 using Thevenin's Theorem.

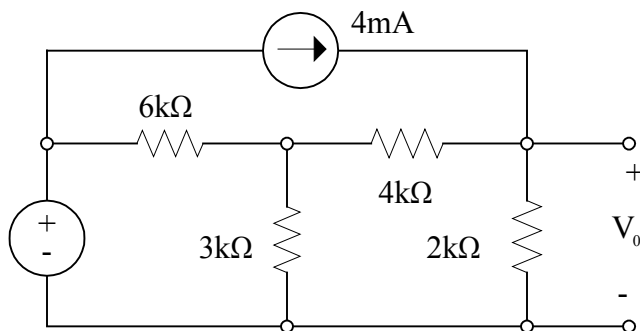

Fig. 5.3

- 5.4 Find I_0 in the circuit in Fig. 5.4 using Norton's Theorem.

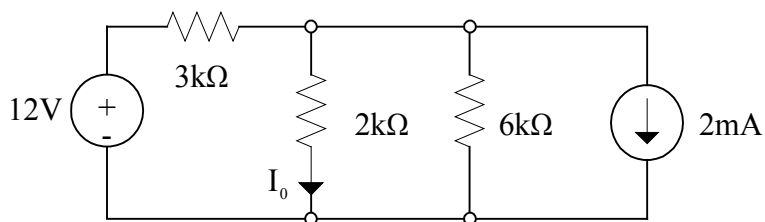

Fig. 5.4

- 5.5 For the network in Fig. 5.5, find R_L for maximum power transfer and the maximum power that can be transferred to this load.

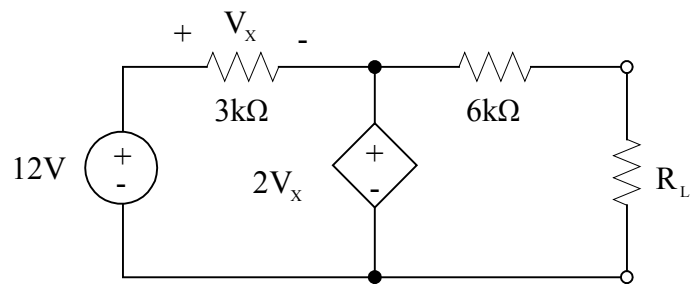

Fig. 5.5

CHAPTER 5 SOLUTIONS

- 5.1 To apply superposition, we consider the contribution that each source independently makes to the output voltage V_o . In so doing, we consider each source operating alone and we zero the other source(s). Recall, that in order to zero a voltage source, we replace it with a short circuit since the voltage across a short circuit is zero. In addition, in order to zero a current source, we replace the current source with an open circuit since there is no current in an open circuit.

Consider now the voltage source acting alone. The network used to obtain this contribution to the output V_o is shown in Fig. S5.1(a).

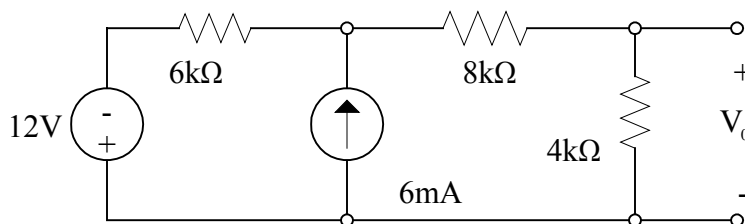

Fig. S5.1(a)

Then V_o' (only a part of V_o) is the contribution due to the 12V source. Using voltage division

$$\begin{aligned} V_o &= -12 \left(\frac{4k}{4k + 6k + 8k} \right) \\ &= -\frac{8}{3} \text{V} \end{aligned}$$

The current source's contribution to V_o is obtained from the network in Fig. S5.1(b).

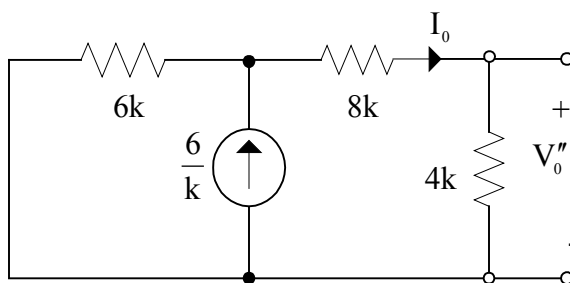

Fig. S5.1(b)

Using current division, we find that

$$\begin{aligned} I_o &= \frac{6}{k} \left(\frac{6k}{6k + 8k + 4k} \right) \\ &= 2\text{mA} \end{aligned}$$

Then

$$\begin{aligned} V_0'' &= 4kI_0 \\ &= 8V \end{aligned}$$

Then superposition states that

$$\begin{aligned} V_0 &= V_0' + V_0'' \\ &= \frac{-8}{3} + 8 = \frac{16}{3} V \end{aligned}$$

- 5.2 Recall that when employing source transformation, at a pair of terminals we can exchange a voltage source V_S in series with a resistor R_S for a current source I_p in parallel with a resistor R_p and vice versa, provided that the following relationships among the parameters exist.

$$\begin{aligned} I_p &= \frac{V_S}{R_S} \\ R_p &= R_S \end{aligned}$$

Now the original circuit is shown in Fig. S5.2(a).

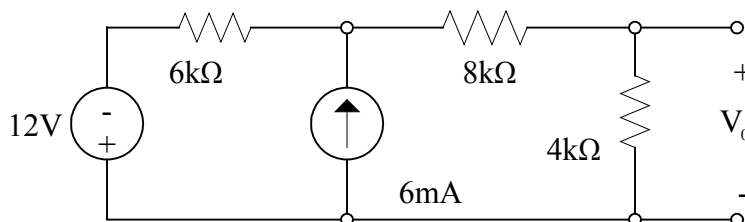

Fig. S5.2(a)

Note that we have a 12V source in series with a 6kΩ resistor that can be exchanged for a current source in parallel with the resistor. This appears to be a viable exchange since we will then have two current sources in parallel which we can add algebraically. Performing the exchange yields the network in Fig. S5.2(b).

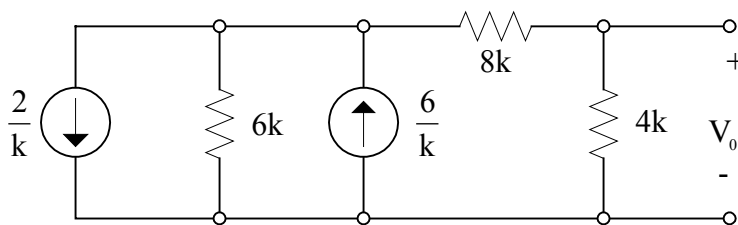

Fig. S5.2(b)

Note that the voltage source was positive at the bottom terminal and therefore the current source points in that direction. Adding the two parallel current sources reduces the network to that shown in Fig. S5.2(c).

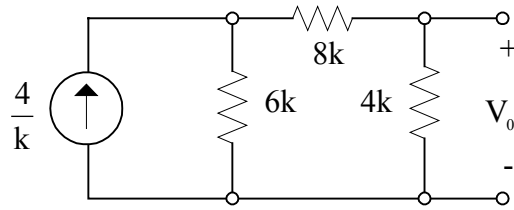

Fig. S5.2(c)

At this point we can apply current division to obtain a solution. For example, the current in the $4\text{k}\Omega$ resistor is

$$\begin{aligned} I_{4\text{k}} &= \frac{4}{\text{k}} \left(\frac{6\text{k}}{6\text{k} + 8\text{k} + 4\text{k}} \right) \\ &= \frac{4}{3} \text{mA} \end{aligned}$$

Then

$$\begin{aligned} V_0 &= (I_{4\text{k}})(4\text{k}) \\ &= \frac{16}{3} \text{V} \end{aligned}$$

However, we could also transform the current source and the parallel $6\text{k}\Omega$ resistor into a voltage source in series with the $6\text{k}\Omega$ resistor before completing the solution. If we make this exchange, then the network becomes that shown in Fig. S5.2(d).

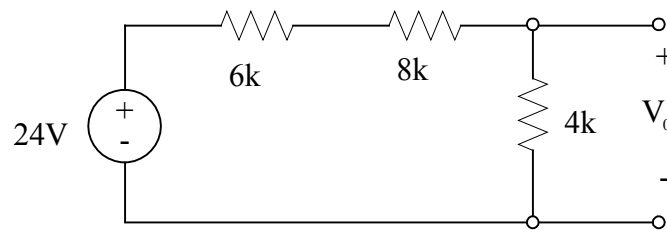

Fig. S5.2(d)

Then using voltage division

$$\begin{aligned} V_0 &= 24 \left(\frac{4\text{k}}{4\text{k} + 6\text{k} + 8\text{k}} \right) \\ &= \frac{16}{3} \text{V} \end{aligned}$$

- 5.3 Since the network contains no dependent source, we will simply determine the open circuit voltage, V_{oc} , and with the sources in the network made zero, we will look into the

open circuit terminals and compute the resistance at these terminals, R_{TH} . The open circuit voltage is determined from the network in Fig. S5.3(a).

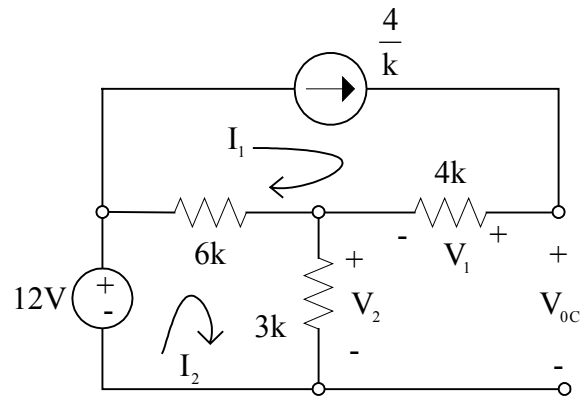

Fig. S5.3(a)

Note the currents and voltages labeled in the network. First of all, note that

$$V_{oc} = V_1 + V_2$$

Therefore, we need only to determine these voltages. Clearly, the voltage V_1 is

$$V_1 = I_1(4k) = 16V$$

However, to find V_2 we need I_2 . KVL around the loop I_2 yields

$$-12 + 6k(I_2 - I_1) + 3kI_2 = 0$$

or

$$\begin{aligned} -12 + 6k\left(I_2 - \frac{4}{k}\right) + 3kI_2 &= 0 \\ I_2 &= \frac{4}{k} = 4mA \end{aligned}$$

Now

$$\begin{aligned} V_{oc} &= V_1 + V_2 \\ &= 4kI_1 + 3kI_2 \\ &= 28V \end{aligned}$$

The Thevenin equivalent resistance is found by zeroing all sources and looking into the open circuit terminals to determine the resistance. The network used for this purpose is shown in Fig. S5.3(b).

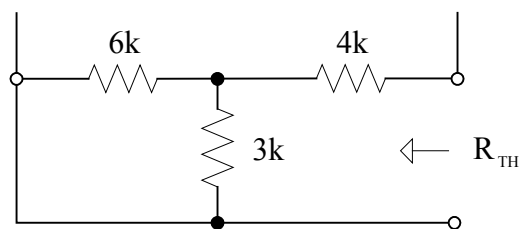

Fig. S5.3(b)

From the network we see that the 6k and 3k Ohm resistors are in parallel and that combination is in series with the 4kΩ resistor. Thus

$$R_{TH} = 4k + 3k \parallel 6k \\ = 6k\Omega$$

Therefore, the Thevenin equivalent circuit consists of the 28V source in series with the 6kΩ resistor. If we connect the 2kΩ resistor to this equivalent network we obtain the circuit in Fig. S5.3(c).

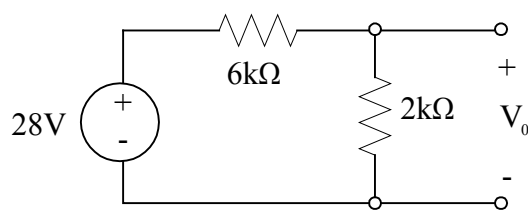

Fig. S5.3(c)

Then using voltage division

$$V_0 = 28 \left(\frac{2k}{2k + 6k} \right) \\ = 7V$$

- 5.4 In this network, the 2kΩ resistor represents the load. In applying Norton's Theorem we will replace the network without the load by a current source, the value of which is equal to the short-circuit current computed from the network in Fig. S5.4(a), in parallel with the Thevenin equivalent resistance determined from Fig. S5.4(b).

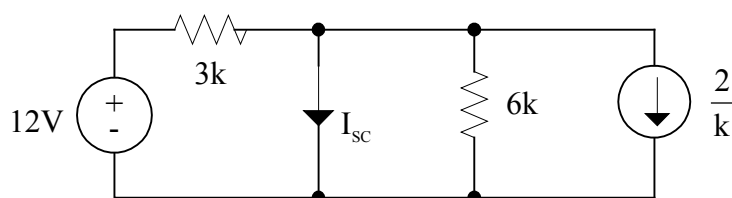

Fig. S5.4(a)

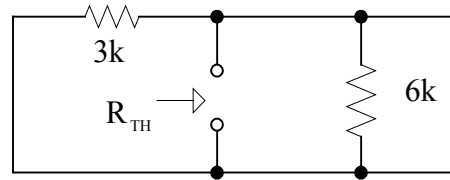

Fig. S5.4(b)

with reference to Fig. S5.4(a), all current emanating from the 12V source will go through the short-circuit. Likewise, all the current in the 2mA current source will also go through the short-circuit so that

$$I_{sc} = \frac{12}{3k} - \frac{2}{k} = 2\text{mA}$$

If this statement is not obvious to the reader, then consider the circuit shown in Fig. S5.4(c).

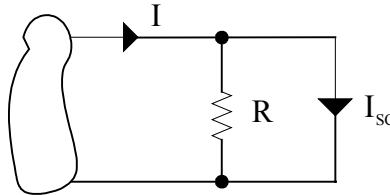

Fig. S5.4(c)

Knowing that the resistance of the short-circuit is zero, we can apply current division to find I_{sc}

$$\begin{aligned} I_{sc} &= I \left(\frac{R}{R + 0} \right) \\ &= I \end{aligned}$$

indicating that all the current in this situation will go through the short-circuit and none of it will go through the resistor. From Fig. S5.4(b) we find that the 3k and 6k Ohm resistors are in parallel and thus

$$R_{TH} = 3k \parallel 6k = 2k\Omega$$

Now the Norton equivalent circuit consists of the short-circuit current in parallel with the Thevenin equivalent resistance as shown in Fig. S5.4(d).

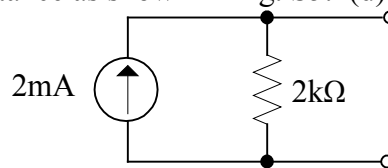

Fig. S5.4(d)

Remember, at the terminals of the $2k\Omega$ load, this network is equivalent to the original network with the load removed. Therefore, if we now connect the load to the Norton equivalent circuit as shown in Fig. S5.4(e), the load current I_0 can be calculated via current division as

$$I_0 = \frac{2}{k} \left(\frac{2k}{2k + 2k} \right)$$

$$= 1 \text{ mA}$$

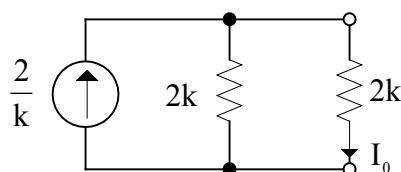

Fig. S5.4(e)

- 5.5 The solution of this problem involves finding the Thevenin equivalent circuit at the terminals of the load resistor R_L and setting R_L equal to the Thevenin equivalent resistance R_{TH} .

To determine the Thevenin equivalent circuit, we first find the open circuit voltage as shown in Fig. S5.5(a).

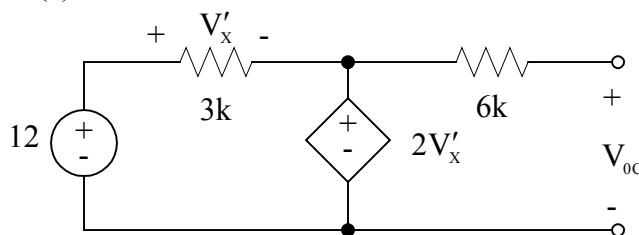

Fig. S5.5(a)

We employ the prime notation on the control variable V_x since the circuit in Fig. S5.5(a) is different than the original network. Applying KVL to the left side of the network yields

$$-12 + V'_x + 2V'_x = 0$$

$$V'_x = 4V$$

Then the open circuit voltage is

$$V_{oc} = 2V'_x$$

$$= 8V$$

since there is no current in the $6k\Omega$ resistor and therefore no voltage drop across it.

Because of the presence of the dependent source we cannot simply look back into the open circuit terminals, with all independent sources made zero, and determine the Thevenin equivalent resistance. We must determine the short-circuit current, I_{SC} and determine R_{TH} from the expression

$$R_{TH} = \frac{V_{OC}}{I_{SC}}$$

I_{SC} is found from the circuit in Fig. S5.5(b).

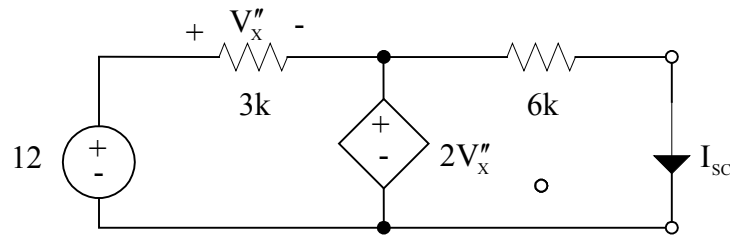

Fig. S5.5(b)

Once again, using KVL

$$\begin{aligned} -12 + V_x'' + 2V_x'' &= 0 \\ V_x'' &= 4 \end{aligned}$$

Then, since the dependent source $2V_x'' = 8V$ is connected directly across the $6k\Omega$ resistor

$$I_{sc} = \frac{2V_x''}{6k} = \frac{2}{3} \text{ mA}$$

and

$$R_{TH} = \frac{V_{OC}}{I_{SC}} = \frac{8}{\frac{2}{3}} = 12k\Omega$$

Hence, for maximum power transfer

$$R_L = R_{TH} = 12k\Omega$$

And the remainder of the problem involves finding the power absorbed by the $12k\Omega$ load, P_L . From the network in Fig. S5.5(c) we find that

$$\begin{aligned} P_L &= I_L^2 R_L \\ &= \left(\frac{8}{24k} \right)^2 (12k) \\ &= 1.33 \text{ mW} \end{aligned}$$

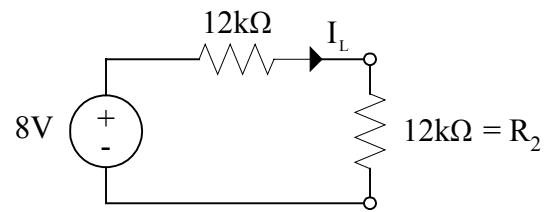

Fig. S5.5(c)

CHAPTER 6 PROBLEMS

- 6.1 If the voltage across a $10\mu\text{F}$ capacitor is shown in Fig. 6.1, derive the waveform for the capacitor current.

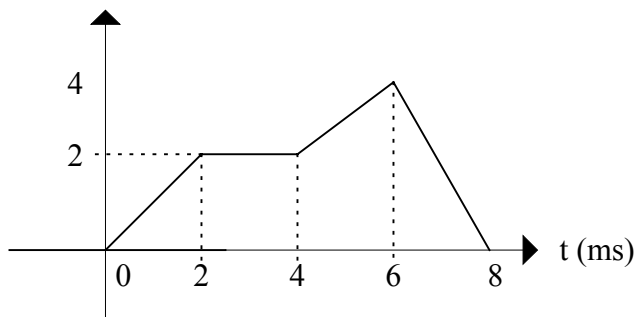

Fig. 6.1

- 6.2 If the voltage across a 100mH inductor is shown in Fig. 6.2, find the waveform for the inductor current.

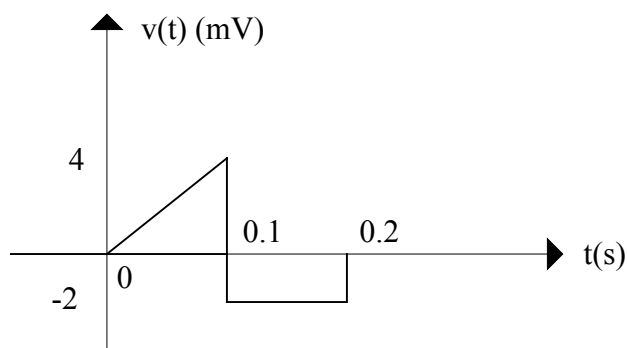

Fig. 6.2

- 6.3 Find the equivalent capacitance of the network in Fig. 6.3 at the terminals A-B. All capacitors are $6\mu\text{F}$.

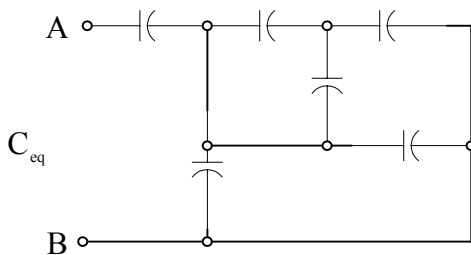

Fig. 6.3

- 6.4 Find the equivalent inductance of the network in Fig. 6.4 at the terminals A-B. All inductors are 12mH .

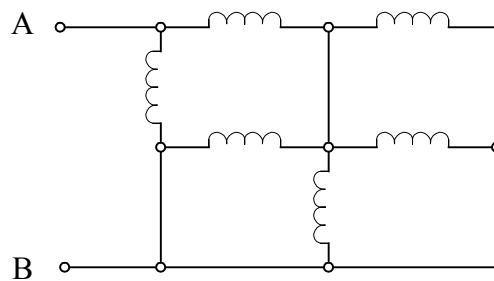

Fig. 6.4

CHAPTER 6 SOLUTIONS

6.1 The equations for the waveforms in the 4 two millisecond time intervals are listed below.

$$\begin{aligned}
 v(t) &= mt + b \\
 &= \frac{2}{2 \times 10^{-3}} t & 0 \leq t \leq 2\text{ms} \\
 &= 2 & 2 \leq t \leq 4\text{ms} \\
 &= -2 + \frac{2}{2 \times 10^{-3}} t & 4 \leq t \leq 6\text{ms} \\
 &= +16 - \frac{4}{2 \times 10^{-3}} t & 6 \leq t \leq 8\text{ms} \\
 &= 0 & t < 0, t > 8\text{ms}
 \end{aligned}$$

Note that within each interval we have simply written the equation of a straight line using the expression $y = mx + b$ or equivalently $v(t) = mt + b$ where m is the slope of the line and b is the point at which the line intersects the $v(t)$ axis.

The equation for the current in a capacitor is

$$i(t) = C \frac{dv(t)}{dt}$$

Using this expression we can compute the current in each interval. For example, in the interval from $0 \leq t \leq 2\text{ms}$

$$\begin{aligned}
 i(t) &= (10 \times 10^{-6}) \frac{d}{dt} \left(\frac{2}{2 \times 10^{-3}} t \right) & 0 \leq t \leq 2\text{ms} \\
 &= 10\text{mA} \\
 i(t) &= (10 \times 10^{-6}) \frac{d}{dt} (2) & 2 \leq t \leq 4\text{ms} \\
 &= 0 \\
 i(t) &= (10 \times 10^{-6}) \frac{d}{dt} \left(-2 + \frac{2}{2 \times 10^{-3}} t \right) & 4 \leq t \leq 6\text{ms} \\
 &= 10\text{mA} \\
 i(t) &= (10 \times 10^{-6}) \frac{d}{dt} \left(16 - \frac{4}{2 \times 10^{-3}} t \right) & 6 \leq t \leq 8\text{ms} \\
 &= -20\text{mA}
 \end{aligned}$$

The waveform for the capacitor current is shown in Fig. S6.1.

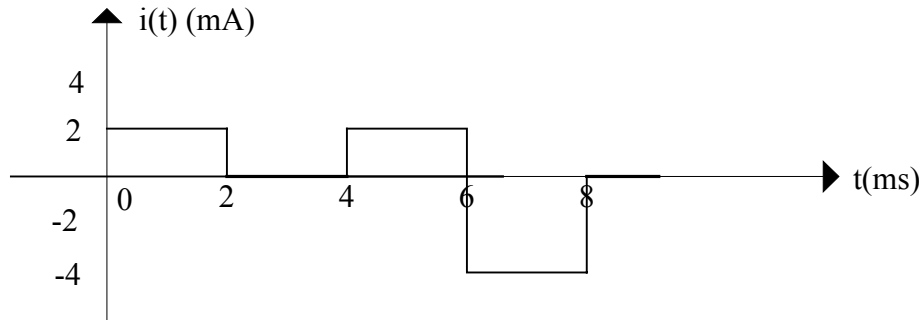

Fig. S6.1

6.2 The general expression for the current in an inductor is

$$i(t) = i(t_0) + \int_{t_0}^t v(x) dx$$

In order to evaluate this function we need the equation of the voltage waveform in the two time intervals $0 \leq t \leq 0.1$ s and $0.1 \leq t \leq 0.2$ s. In the first case, the voltage function is a straight line and the function passes through the origin of the graph. The equation of a straight line on this graph is

$$v(t) = mt + b$$

where m is the slope of the line and b is the point at which the line intersects the $v(t)$ axis.

Since the slope is $\frac{4 \times 10^{-3}}{0.1}$, the equation of the line is

$$v(t) = \frac{4 \times 10^{-3}}{0.1} t$$

where $v(t)$ is measured in volts and time is measured in seconds i.e., the slope has units of volts/sec. Therefore,

$$i(t) = i(0) + \frac{1}{L} \int_0^t \frac{4 \times 10^{-3}}{0.1} \times dx$$

since there is no initial current in the inductor $i(t) = 0$ and $\frac{1}{L} = 10$

$$i(t) = 10 \int_0^t 4 \times 10^{-2} \times dx$$

or

$$\begin{aligned}
 i(t) &= 0.4 \int_0^t x \, dx = 0.4 \frac{x^2}{2} \Big|_0^t \\
 &= 0.2t^2 \text{ A} = 200t^2 \text{ mA}
 \end{aligned}$$

Since the initial current for the second time interval is determined by the value of the current at the end of the first time interval we calculate

$$\begin{aligned}
 i(t) \Big|_{t=0.1} &= 200t^2 \Big|_{t=0.1} \text{ mA} \\
 &= 2 \text{ mA}
 \end{aligned}$$

Therefore, in the time interval $0.1 \leq t \leq 0.2$ s

$$i(t) = i(0.1) + \frac{1}{L} \int_{0.1}^t v(x) \, dx$$

Note that in this interval $v(x)$ is a constant -2 mV or -2×10^{-3} V. Hence,

$$\begin{aligned}
 i(t) &= 2 \times 10^{-3} + 10 \int_{0.1}^t (-2 \times 10^{-3}) \, dx \\
 &= 2 \times 10^{-3} - 20 \times 10^{-3} \times \Big|_{0.1}^t \\
 &= (4 - 20t) \text{ mA}
 \end{aligned}$$

If we now plot the two functions for the current within their respective time intervals we obtain the plot in Fig. S6.2.

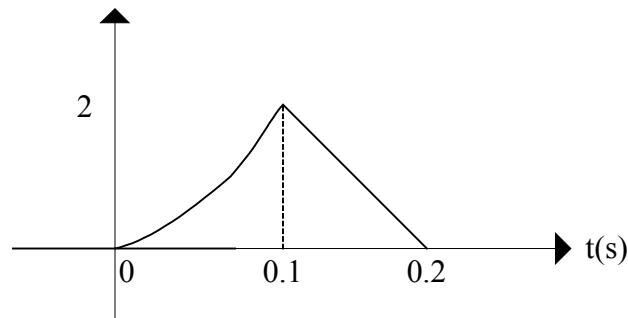

Fig. S6.2

- 6.3 To begin our analysis we first label all the capacitors and nodes in the network as shown in Fig. S6.3(a).

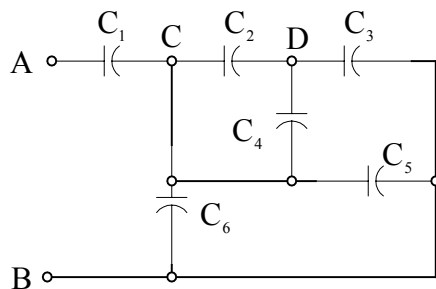

Fig. S6.3(a)

First of all, the reader should note that all the nodes have been labeled, i.e., there are no other nodes. As we examine the topology of the network we find that since C_3 and C_5 are both connected to node D the network can be redrawn as shown in Fig. S6.3(b).

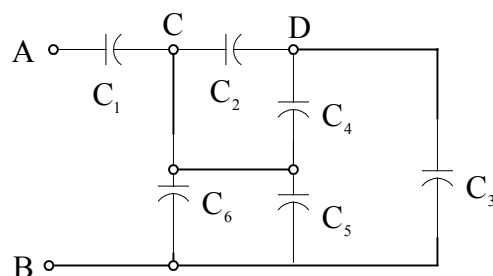

Fig. S6.3(b)

Clearly, C_5 and C_6 are in parallel and their combination we will call $C_{56} = C_5 \parallel C_6$. Combining these two capacitors reduces the network to that shown in Fig. S6.3(c).

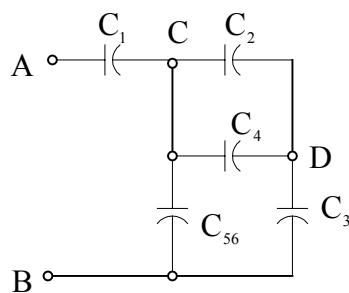

Fig. S6.3(c)

At this point we find that C_2 and C_4 are in parallel and their combination, which we call $C_{24} = C_2 \parallel C_4$, reduces the network to that shown in Fig. S6.3(d).

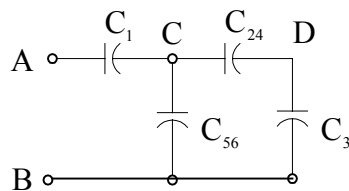

Fig. S6.3(d)

If we now use the given capacitor values, the network becomes that shown in Fig. S6.3(e).

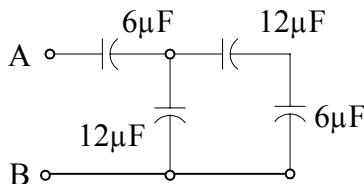

Fig. S6.3(e)

Starting at the opposite end of the network from the terminals A-B and combining elements we find that $6\mu\text{F}$ in series with $12\mu\text{F}$ is $4\mu\text{F}$ and this equivalent capacitance is in parallel with $12\mu\text{F}$ yielding $16\mu\text{F}$, which in turn is in series with $6\mu\text{F}$ producing a total capacitance of

$$\begin{aligned} C_{\text{eq}} &= 6\mu\text{F} \parallel 16\mu\text{F} \\ &= 4.36\mu\text{F} \end{aligned}$$

6.4 To aid our analysis, we will first label all inductors and nodes as shown in Fig. S6.4(a).

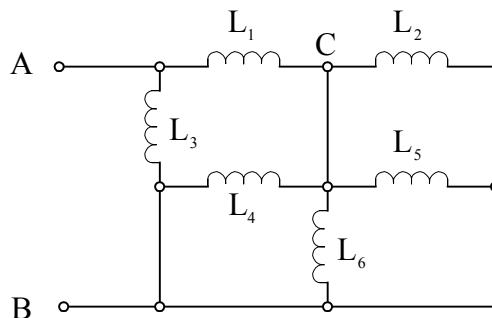

Fig. S6.4(a)

Note carefully that all the nodes have been labeled. Once readers recognize that there are no other nodes, they are well on their way to reducing the network since this node recognition provides data indicating which elements are in series or parallel. For example, since one end of L_4 is connected to node B, the network can be redrawn as shown in Fig. S6.4(b).

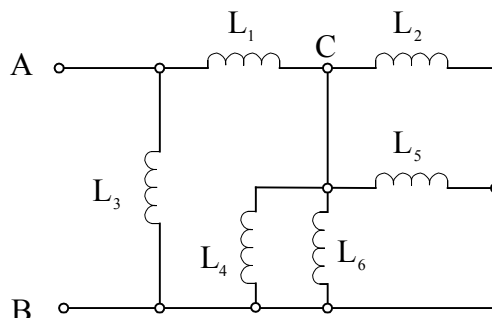

Fig. S6.4(b)

This diagram clearly indicates that L_2 and L_5 are in parallel. In addition, L_4 and L_6 are in parallel. Therefore, if we combine elements so that $L_{25} = L_2 \parallel L_5$ and $L_{46} = L_4 \parallel L_6$, then the circuit can be reduced to that in Fig. S6.4(c).

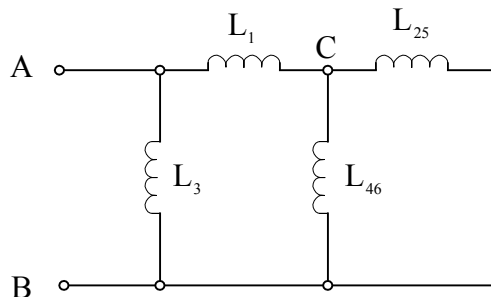

Fig. S6.4(c)

However, we note now if we did not see it earlier that L_{25} is in parallel with L_{46} so that the network can be reduced to that shown in Fig. S6.4(d).

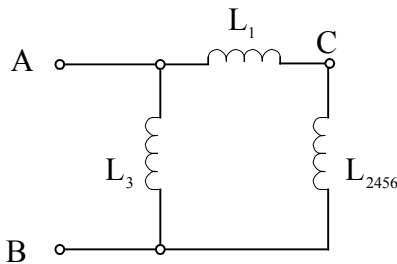

Fig. S6.4(d)

Where $L_{2456} = L_{25} \parallel L_{46}$. Since all inductors are 12mH, $L_{2456} = 3\text{mH}$ which is in series with 12mH and that combination is in parallel with 12mH yielding

$$L_{AB} = 12\text{mH} \parallel 15\text{mH} = 6.66\text{mH}$$

CHAPTER 7 PROBLEMS

- 7.1 Use the differential equation approach to find $i_o(t)$ for $t > 0$ in the circuit in Fig. 7.1 and plot the response including the time interval just prior to opening the switch.

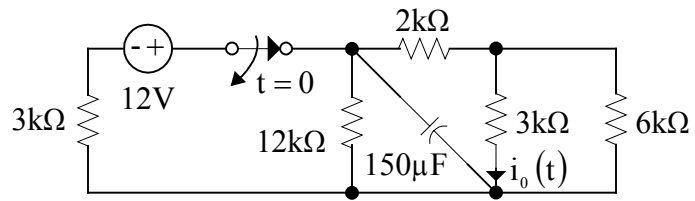

Fig. 7.1

- 7.2 Use the differential equation approach to find $i(t)$ for $t > 0$ in the circuit in Fig. 7.2 and plot the response including the time interval just prior to opening the switch.

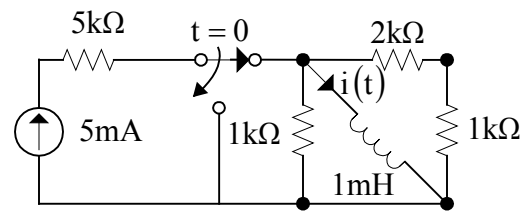

Fig. 7.2

- 7.3 Use the step-by-step technique to find $v_o(t)$ for $t > 0$ in the circuit in Fig. 7.3.

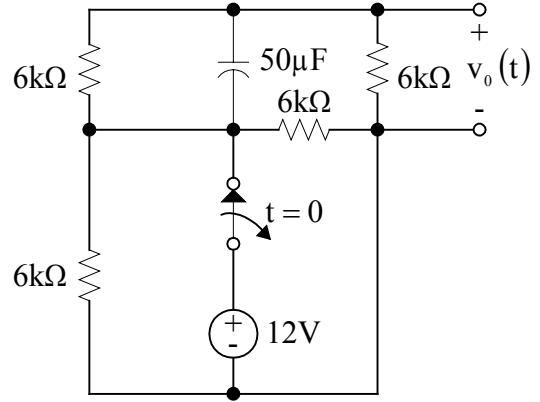

Fig. 7.3

- 7.4 Use the step-by-step method to find $v_o(t)$ for $t > 0$ in the network in Fig. 7.4.

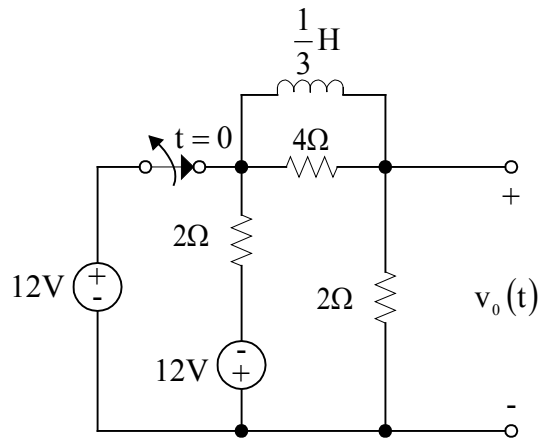

Fig. 7.4

- 7.5 Given the network in Fig. 7.5, find
- the differential equation that describes the current $i(t)$
 - the characteristic equation for the network
 - the network's natural frequencies
 - the type of damping exhibited by the circuit
 - the general expression for $i(t)$

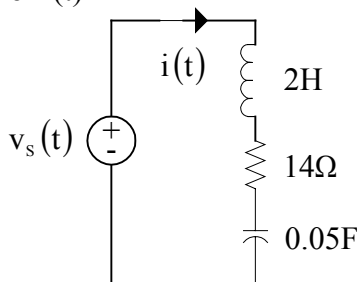

Fig. 7.5

- 7.6 Find $i_0(t)$ for $t > 0$ in the circuit in Fig. 7.6 and plot the response including the time interval just prior to closing the switch.

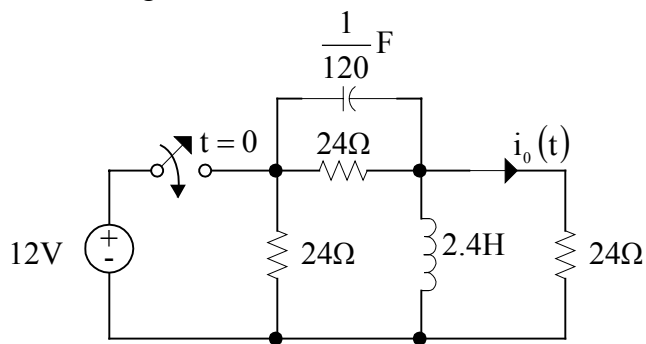

Fig. 7.6

CHAPTER 7 SOLUTIONS

- 7.1 We begin our solution by redrawing the network and labeling all the components as shown in Fig. S7.1(a)

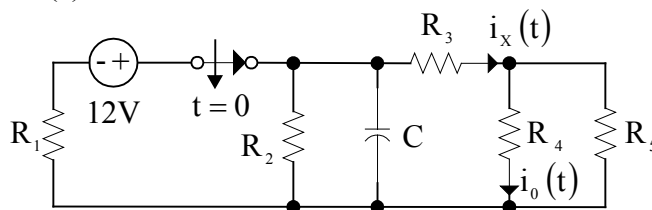

Fig. S7.1(a)

In order to determine the initial condition of the network prior to switch action, we must determine the initial voltage across the capacitor. A circuit, which can be used for this purpose, is shown in Fig. S7.1(b).

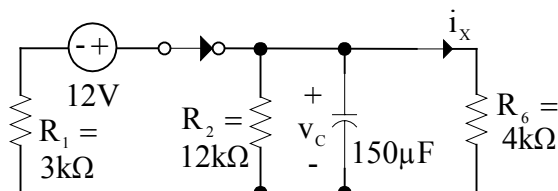

Fig. S7.1(b)

Where we have combined the resistors at the right end of the network so that

$$\begin{aligned} R_6 &= R_3 + R_4 \parallel R_5 \\ &= 2\text{k} + 3\text{k} \parallel 6\text{k} \\ &= 4\text{k}\Omega \end{aligned}$$

In the steady-state condition before the switch is thrown, the capacitor looks like an open-circuit and therefore $v_c(0-)$ is the voltage across the parallel combination of R_2 and R_6 . Using voltage division, the 12V source will produce the voltage

$$\begin{aligned} v_c(0-) &= 12 \left(\frac{R_2 \parallel R_6}{R_1 + R_2 \parallel R_6} \right) \\ &= 12 \left(\frac{3\text{k}}{3\text{k} + 3\text{k}} \right) = 6\text{V} \end{aligned}$$

Now that the initial voltage across the capacitor is known, we can find the initial value of the current $i_0(t)$. From Fig. S7.1(b) we see that

$$i_x(0-) = \frac{v_c(0-)}{R_6} = \frac{6}{4\text{k}} = 1.5\text{mA}$$

Then, using current division as shown in Fig. S7.1(a),

$$\begin{aligned} i_0(0^-) &= \frac{i_x(0^-)(R_5)}{R_4 + R_5} \\ &= \frac{\left(\frac{3}{2k}\right)(6k)}{3k + 6k} = 1\text{mA} \end{aligned}$$

The parameters for $t < 0$ are now known. For the time interval $t > 0$, the network is reduced to that shown in Fig. S7.1(c).

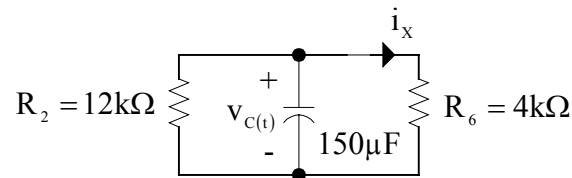

Fig. S7.1(c)

Applying KCL to this network yields

$$C \frac{dv_c(t)}{dt} + \frac{v_c(t)}{R_2} + \frac{v_c(t)}{R_6} = 0$$

or using the parameter values

$$\frac{dv_c(t)}{dt} + \frac{20}{9} v_c(t) = 0$$

The solution of this differential equations of the form

$$v_c(t) = k_1 + k_2 e^{\frac{-t}{\tau}}$$

Since the differential equation has no constant forcing function, we know that $k_1 = 0$.

Therefore, substituting $v_c(t) = k_2 e^{\frac{-t}{\tau}}$ into the equation yields

$$\frac{-t}{\tau} k_2 e^{\frac{-t}{\tau}} + \frac{20}{9} k_2 e^{\frac{-t}{\tau}} = 0$$

and

$$\tau = \frac{9}{20} \text{ sec.}$$

In addition, since

$$v_C(0) = 6 = k_2 e^0$$

$$k_2 = 6$$

Thus

$$v_C(t) = 6e^{-\frac{20}{9}t} \text{ V}$$

Recall that

$$i_0(t) = i_x(t) \frac{R_5}{R_4 + R_5}$$

and

$$i_x(t) = \frac{v_C(t)}{R_6}$$

Then

$$i_0(t) = \left(\frac{v_C(t)}{R_6} \right) \left(\frac{R_5}{R_4 + R_5} \right)$$

$$= 1e^{-\frac{20}{9}t} \text{ mA} \quad t > 0$$

$$= 1 \text{ mA} \quad t < 0$$

7.2 The network can be redrawn as shown in Fig. S7.2(a).

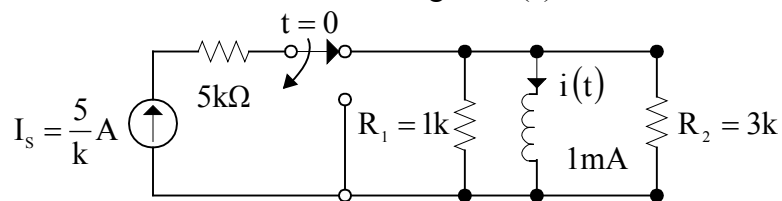

Fig. S7.2(a)

In the steady-state time interval prior to switch action, the inductor looks like a short-circuit. Therefore, in this time period $t < 0$, the initial inductor current is

$$i_L(0^-) = I_s = 5 \text{ mA}$$

At $t = 0$ the switch changes positions and hence for $t > 0$ the network reduces to that shown in Fig. S7.2(b).

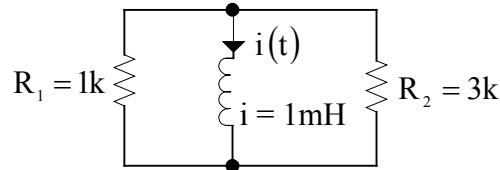

Fig. S7.2(b)

If we let $R = R_1 \parallel R_2$ then the differential equation for the inductor current is

$$L \frac{di(t)}{dt} + R i(t) = 0$$

The solution of this equation is of the form

$$i(t) = k_1 + k_2 e^{-\frac{t}{\tau}}$$

The differential equation has no constant forcing function and hence $k_1 = 0$. Substituting $i(t) = k_2 e^{-\frac{t}{\tau}}$ into the equation for the current yields

$$\left(\frac{1}{k}\right)\left(\frac{-t}{\tau}\right)k_2 e^{-\frac{t}{\tau}} + \left(\frac{3k}{4}\right)k_2 e^{-\frac{t}{\tau}} = 0$$

where we have used the circuit parameter values in the equation, i.e., $L = \frac{1}{k}$ H and

$R = \frac{3}{4k} \Omega$. This equation produces a τ value of

$$\tau = \frac{4}{3} \mu \text{ sec.}$$

Furthermore, since

$$i(0^-) = 1 \text{ mA}$$

and

$$i(0) = k_2 e^{-0}$$

we find that

$$k_2 = 5 \text{ mA}$$

Therefore,

$$i(t) = 5\text{mA}, \quad t < 0$$

$$= 5e^{-7.5 \times 10^5 t} \text{mA}, \quad t > 0$$

7.3 The circuit is redrawn for convenience in Fig. S7.3(a).

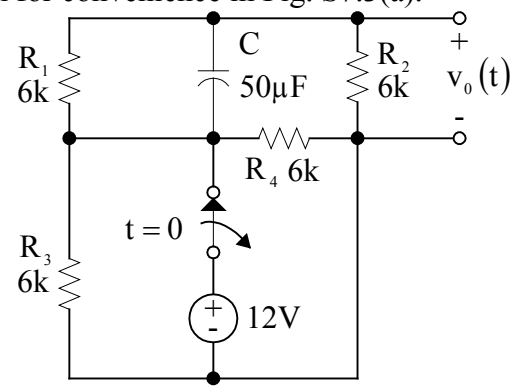

Fig. S7.3(a)

Before we begin our analysis, we note that resistors R_3 and R_4 are in parallel and so we first reduce the network to that shown in Fig. S7.3(b).

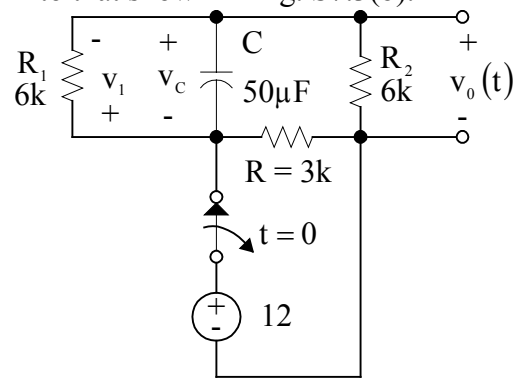

Fig. S7.3(b)

Now that the network has been simplified, we begin our analysis

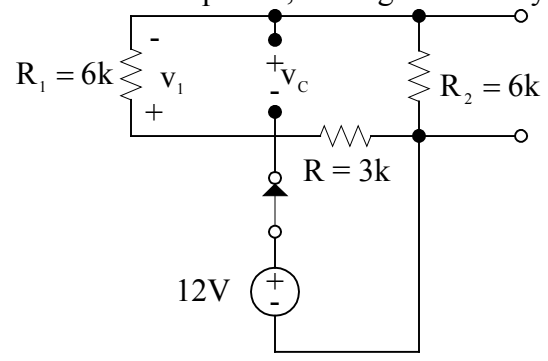
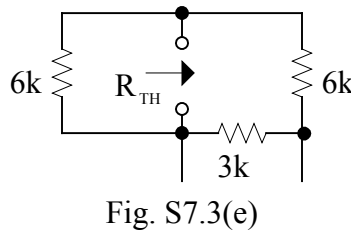
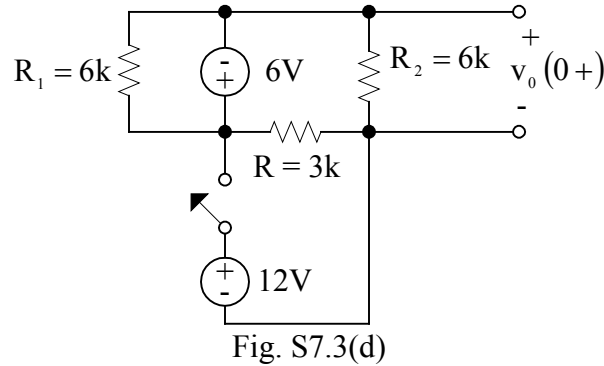

Fig. S7.3(c)



Step-1 $v_0(t) = k_1 + k_2 e^{-\frac{t}{\tau}}$

Step-2 In steady-state prior to switch action, the capacitor looks like an open-circuit and the 12-V source is directly across the resistor $R = 3k\Omega$. As shown in Fig. S7.3(c) the voltage v_1 across R_1 is equal and opposite to v_C . Since the voltage of the 12-V source is divided between R_1 and R_2 we can use voltage division to find v_1 as

$$v_1 = 12 \left(\frac{R_1}{R_1 + R_2} \right) = 6V$$

hence

$$v_C(0-) = -v_1 = -6V = v_C(0+)$$

Step-3 The new circuit, valid only for $t = 0+$ is shown in Fig. S7.3(d). Once again, using voltage division,

$$\begin{aligned} v_0(0+) &= -v_C(0+) \left(\frac{R_2}{R_2 + R} \right) \\ &= -4V \end{aligned}$$

Step-4 For the period $t > 5\tau$, the capacitor looks like an open-circuit and the source is disconnected. With no source of energy present in the network

$$v_0(\infty) = 0$$

Step-5 The Thevenin equivalent resistance obtained by looking into the network from the terminals of the capacitor with all sources made zero is derived from the circuit in Fig. S7.3(e)

$$\begin{aligned} R_{TH} &= (6k) \parallel (6k + 3k) \\ &= 3.6k\Omega \end{aligned}$$

Then the time constant of the network is

$$\begin{aligned} \tau &= R_{TH}C \\ &= 0.18 \text{ sec.} \end{aligned}$$

Step-6 Evaluating the constants in the solution, we find that

$$\begin{aligned} k_1 &= v_o(\infty) = 0 \\ k_2 &= v_o(0+) - v_o(\infty) = -4 \end{aligned}$$

Therefore,

$$v_o(t) = -4e^{\frac{-t}{0.18}} \text{ V}$$

7.4 We begin our analysis of the network with

Step-1 The output voltage will be of the form

$$v_o(t) = k_1 + k_2 e^{\frac{-t}{\tau}}$$

Step-2 In the steady-state prior to the time the switch is thrown, the inductor acts like a short-circuit and shorts out the 4Ω resistor. The network for this situation is as shown in Fig. S7.4(a).

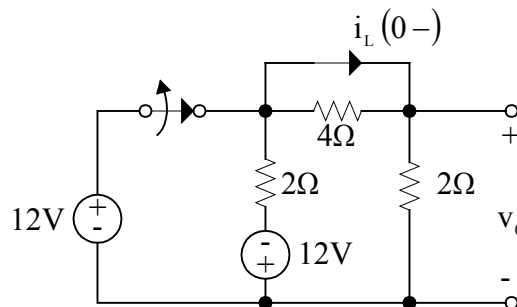

Fig. S7.4(a)

Under these conditions, $i_L(0-)$ is the current from the 12-V source at the left side of the network, through the short-circuit, with a return path through the 2Ω resistor at the

output. What is the contribution of the 12V source in the center of the network? No contribution! Why? If we applied superposition and treated each source independently, we would quickly find that when the left-most source was replaced with a short-circuit, all the current from the other 12-V source would be diverted through this short-circuit. Therefore,

$$i_L(0^-) = \frac{12}{2} = 6\text{A} = i_L(0^+)$$

Step-3 The new network, valid only for $t = 0^+$, is shown in Fig. S7.4(b).

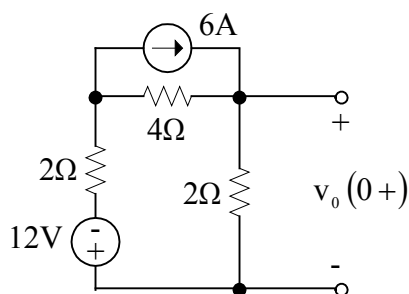

Fig. S7.4(b)

If we employ superposition, we find that

$$\begin{aligned} v_o(0^+) &= -12 \left(\frac{2}{2+4+2} \right) + 6 \left(\frac{4}{4+2+2} \right) (2) \\ &= 3\text{V} \end{aligned}$$

where in this equation we have used first voltage division in conjunction with current division to obtain the voltage. The two networks employed are shown in Figs. S7.4(c) and (d).

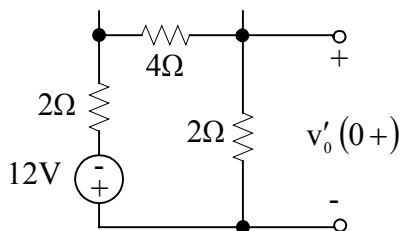

Fig. S7.4(c)

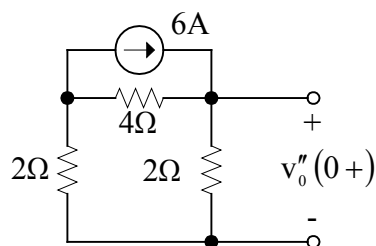
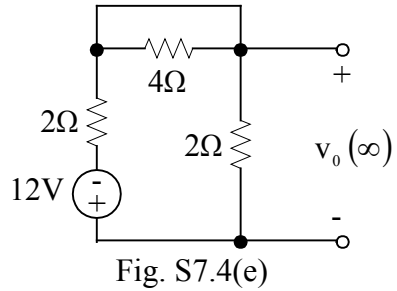

Fig. S7.4(d)

Step-4 For $t > 5\tau$, the inductor again looks like a short-circuit and the network is of the form shown in Fig. S7.4(e).



A simple voltage divider indicates that the output voltage is

$$v_o(\infty) = -12 \left(\frac{2}{2+2} \right) = -6V$$

Step-5 The Thevenin equivalent resistance obtained by looking into the circuit from the terminals of the inductor with all sources made zero is derived from the network in Fig. S7.4(f).

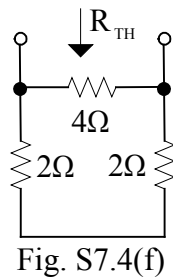

Clearly

$$R_{TH} = 4 \parallel (2 + 2) = 2\Omega$$

Then the time constant is

$$\tau = \frac{L}{R} = \frac{1}{2} = \frac{1}{6} \text{ sec.}$$

Step-6 The solution constants are then

$$\begin{aligned} k_1 &= v_o(\infty) = -6 \\ k_2 &= v_o(0+) - v_o(\infty) \\ &= 3 - (-6) = 9V \end{aligned}$$

Hence,

$$v_o(t) = -6 + 9e^{-6t} \text{ V}$$

7.5 (a) Applying KVL to the closed path yields

$$v_s(t) = Ri(t) + \frac{1}{C} \int_{t_0}^t i(x) dx + L \frac{di(t)}{dt}$$

differentiating both sides of the equation we obtain

$$\frac{dv_s(t)}{dt} = R \frac{di(t)}{dt} + \frac{i(t)}{C} + L \frac{d^2i(t)}{dt^2}$$

By rearranging the terms, the equation can be expressed in the form

$$L \frac{d^2i(t)}{dt^2} + R \frac{di(t)}{dt} + \frac{i(t)}{C} = \frac{dv_s(t)}{dt}$$

or

$$\frac{d^2i(t)}{dt^2} + \frac{R}{L} \frac{di(t)}{dt} + \frac{1}{RC} i(t) = \frac{1}{L} \frac{dv_s(t)}{dt}$$

Using the circuit component values yields

$$\frac{d^2i(t)}{dt^2} + 7 \frac{di(t)}{dt} + 10 i(t) = \frac{1}{2} \frac{dv_s(t)}{dt}$$

(b) The characteristic equation for the network is

$$s^2 + 7s + 10 = 0$$

(c) The network's natural frequencies are the roots of the characteristic equation. The quadratic formula could be used to obtain those roots or we can simply recognize that the equation can be expressed in the form

$$s^2 + 7s + 10 = (s + 2)(s + 5) = 0$$

Therefore, the networks natural frequencies are

$$\begin{aligned} s &= 2 \\ s &= 5 \end{aligned}$$

(d) Since the roots of the characteristic equation are real and unequal, the network response is overdamped.

(e) Based upon the above analysis, the general expression for the current is

$$i(t) = k_0 + k_1 e^{-2t} + k_2 e^{-5t} \text{ A}$$

where k_0 is the steady-state value and the constants k_1 and k_2 are determined from initial conditions.

7.6 The network is re-labeled as shown in Fig. S7.6(a).

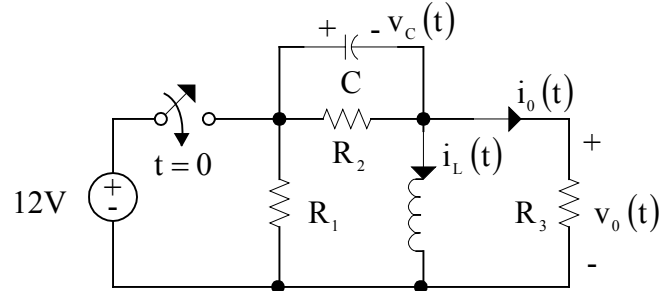

Fig. S7.6(a)

where all $R = 24\Omega$, $L = 2.4\text{H}$ and $C = \frac{1}{120}\text{F}$. Consider now the conditions of the network at three critical points in time.

At $t = 0^-$, i.e., the steady-state condition prior to switch action, the capacitor acts like an open-circuit, the inductor acts like a short-circuit and hence $v_c(0^-) = 0$, $i_L(0^-) = 0$, $i_o(0^-) = 0$ and $v_o(0^-) = 0$.

At $t = 0^+$, i.e., the instant the switch is thrown, the conditions on the storage elements (L and C) cannot change instantaneously and therefore $v_c(0^+) = 0$, $i_L(0^+) = 0$,

$$i_o(0^+) = \frac{12}{R_3} = \frac{1}{2} \text{ A} \text{ and } v_o(0^+) = 12\text{V}.$$

At $t = \infty$, i.e., the steady-state condition after the switch is thrown, the capacitor acts like an open-circuit, the inductor acts like a short-circuit and hence $v_c(\infty) = 12\text{V}$,

$$i_L(\infty) = \frac{12}{R_2} = \frac{1}{2} \text{ A}, \quad i_o(\infty) = 0 \text{ and } v_o(\infty) = 0.$$

Now applying KCL to the network in the time interval $t > 0$, we obtain

$$\frac{12 - v_o(t)}{R_2} + C \frac{d(12 - v_o(t))}{dt} = \frac{1}{L} \int_0^t v_o(x) dx + \frac{v_o(t)}{R_3}$$

where $i_0(t) = \frac{v_0(t)}{R_3}$ expressing $v_0(t)$ in terms of $i_0(t)$ and using the component values reduces the equation to

$$\frac{1}{2} - i_0(t) - \frac{1}{5} \frac{di_0(t)}{dt} - 10 \int_0^t i_0(x) dx - i_0(t) = 0$$

Combining terms and differentiating this expression yields

$$\frac{d^2 i_0(t)}{dt^2} + 10 \frac{di_0(t)}{dt} + 50 i_0(t) = 0$$

Therefore, the characteristic equation for the network is

$$s^2 + 10s + 50 = 0$$

Factoring this equation using the quadratic formula or any other convenient means yields

$$s_1, s_2 = -5 \pm j5 = \sigma \pm j\omega$$

Since the roots of the characteristic equation are complex conjugates, the network is underdamped and the general form of the current $i_0(t)$ is

$$\begin{aligned} i_0(t) &= k + e^{-\sigma t} (A \cos \omega t + B \sin \omega t) \\ &= k + e^{-5t} (A \cos 5t + B \sin 5t) \end{aligned}$$

where k is the steady-state term resulting from the presence of the voltage source in the time interval $t \rightarrow \infty$.

We can now evaluate the constants k , A and B using the known conditions for the network. For example,

$$i_0(0+) = \frac{1}{2} = k + A$$

and

$$i_0(\infty) = 0 = k$$

Therefore, $k = 0$ and $A = \frac{1}{2}$.

We need another equation in order to evaluate the constant B. If we return to our original equation and evaluate it at time $t = 0+$, we have

$$\frac{12 - 12}{R_2} + \frac{1}{120} \left(\frac{-dv_0(t)}{dt} \right) \Big|_{t=0+} = 0 + \frac{12}{R_3}$$

where $v_0(0+) = 12V$, the integration interval is zero and the derivative function is our unknown. Therefore,

$$\frac{dv_0(t)}{dt} \Big|_{t=0+} = -60$$

or

$$\frac{di_0(t)}{dt} \Big|_{t=0+} = -2.5$$

The general form of the solution is

$$i_0(t) = e^{-5t} \left(\frac{1}{2} \cos 5t + B \sin 5t \right)$$

Then

$$\frac{di_0(t)}{dt} = -5e^{-5t} \left(\frac{1}{2} \cos 5t \right) + e^{-5t} \left(\frac{-5}{2} \sin 5t \right) - 5e^{-5t} B \sin 5t + e^{-5t} 5B \cos 5t$$

and

$$\frac{di_0(t)}{dt} \Big|_{t=0+} = \frac{-5}{2} + 5B$$

Therefore,

$$-2.5 = \frac{-5}{2} + 5B$$

or

$$B = 0$$

The general solution is then

$$\begin{aligned} i_0(t) &= 0 & t < 0 \\ &= \frac{1}{2} e^{-5t} \cos 5t & t > 0 \end{aligned}$$

A plot of this function is shown in Fig. S7.6(b).

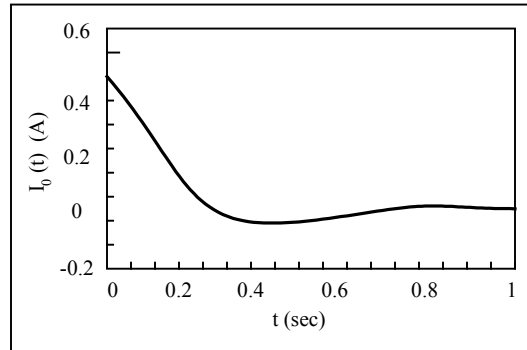

Fig. S7.6(b)

CHAPTER 8 PROBLEMS

- 8.1 Find the frequency domain impedance Z , shown in Fig. 8.1.

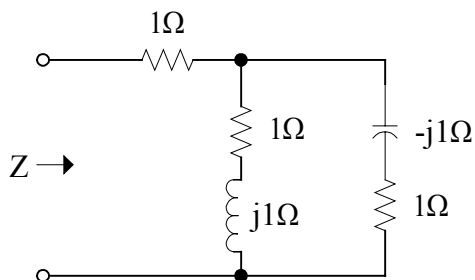

Fig. 8.1

- 8.2 If the impedance of the network in Fig. 8.2 is real at $f = 60\text{Hz}$, what is the value of the inductor L ?

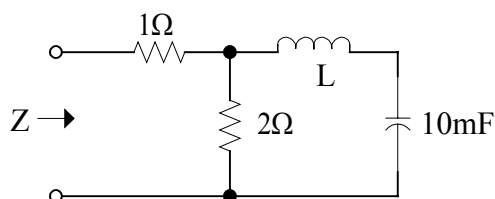

Fig. 8.2

- 8.3 Use nodal analysis to find V_0 in the network in Fig. 8.3.

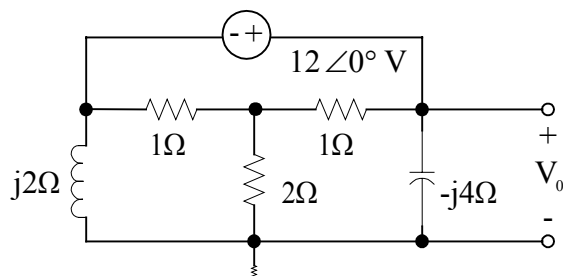

Fig. 8.3

- 8.4 Find V_0 in the network in Fig. 8.4 using (a) loop analysis (b) superposition and (c) Thevenin's Theorem.

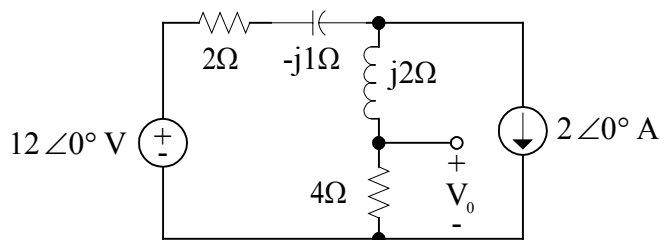

Fig. 8.4

CHAPTER 8 SOLUTIONS

- 8.1. To begin our analysis, we note that the circuit can be labeled as shown in Fig. S8.1.

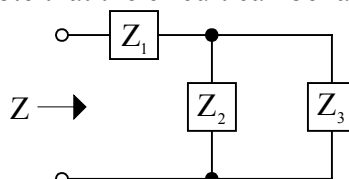

Fig. S8.1

In this case, Z_1 consists of a 1Ω resistor, Z_2 is the series combination of a 1Ω resistor and a $j1\Omega$ inductor and Z_3 consists of a $-j1\Omega$ capacitor in series with a 1Ω resistor. Therefore,

$$\begin{aligned} Z_1 &= 1\Omega \\ Z_2 &= 1 + j1\Omega \\ Z_3 &= 1 - j1\Omega \end{aligned}$$

Starting at the opposite end of the network from the terminals at which Z is calculated we note that Z_2 and Z_3 are in parallel and their combination is in series with Z_1 . Hence

$$\begin{aligned} Z &= Z_1 + Z_2 \parallel Z_3 \\ &= 1 + \frac{(1 + j)(1 - j)}{1 + j + 1 - j} \\ &= 1 + \frac{2}{2} \\ &= 2\Omega \end{aligned}$$

- 8.2 The general expression for the impedance of this network is

$$Z = 1 + 2 \parallel \left(j\omega L + \frac{1}{j\omega C} \right)$$

In order for Z to be purely resistive, the term $\left(j\omega L + \frac{1}{j\omega C} \right)$ must be real, i.e.

$$Z_{LC} = R_{LC} + j0$$

However, since Z_{LC} can be written as

$$Z_{LC} = j \left(\omega L - \frac{1}{\omega C} \right)$$

it is clearly an imaginary term and $R_{LC} = 0$. Therefore, in order for Z to be resistive

$$\omega L - \frac{1}{\omega C} = 0$$

or

$$\begin{aligned} L &= \frac{1}{\omega^2 C} \\ &= \frac{1}{(377)^2 (10^{-2})} \\ &= 703.6 \mu\text{H} \end{aligned}$$

- 8.3 The presence of the voltage source indicates that nodal analysis is a viable approach to this problem. The voltage source and its two connecting nodes form a supernode as shown in Fig. S8.3.

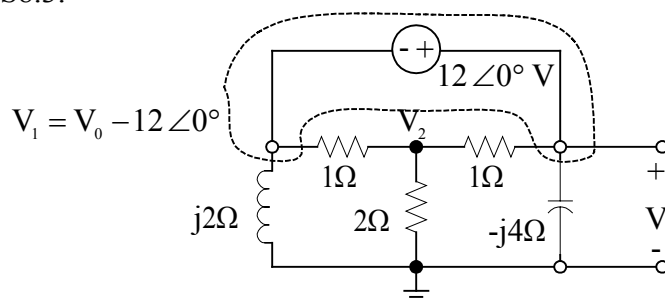

Fig. S8.3

Note that there are three non-reference nodes, i.e., V_1 , V_2 and V_0 . Because the voltage source is tied directly between nodes V_1 and V_0 , $V_1 = V_0 - 12\angle 0^\circ$. This constraint condition is one of our three equations required to solve the network. The two remaining equations are obtained by applying KCL at the supernode and the node labeled V_2 . For the supernode, KCL yields

$$\frac{V_1}{j2} + \frac{V_1 - V_2}{1} + \frac{V_0 - V_2}{1} + \frac{V_0}{-j4} = 0$$

At the node labeled V_2 , KCL yields

$$\frac{V_2 - V_1}{1} + \frac{V_2}{2} + \frac{V_2 - V_0}{1} = 0$$

Therefore, the three equations that will provide the node voltages are

$$V_1 = V_0 - 12$$

$$-j\frac{1}{2}V_1 + V_1 - V_2 + V_0 - V_2 + j\frac{1}{4}V_0 = 0$$

$$V_2 - V_1 + \frac{1}{2}V_2 + V_2 - V_0 = 0$$

Substituting the first equation in for the two remaining equations and combining terms yields

$$V_0 \left(2 - j\frac{1}{4} \right) - 2V_2 = 12 - j6$$

$$-2V_0 + \frac{5}{2}V_2 = -12$$

Solving for V_2 in this last equation and substituting it into the one above it, we obtain

$$V_0 (0.4 - j0.25) = 2.4 - j6$$

and hence

$$V_0 = 13.57 \angle -36.2^\circ \text{ V}$$

- 8.4 (a) Since the network has two loops, or in this case two meshes, we will need two equations to determine all the currents. Consider the network as labeled in Fig. S8.4(a).

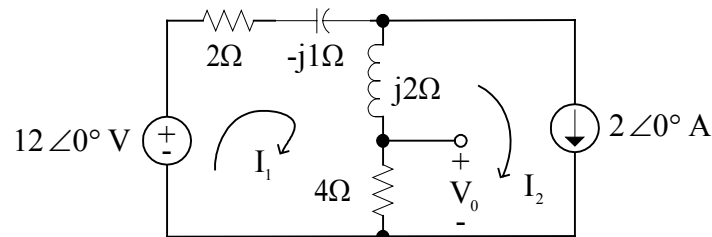

Fig. S8.4(a)

Note that since I_2 goes directly through the current source, I_2 must be $2\angle 0^\circ$ A. Hence, one of our two equations is

$$I_2 = 2\angle 0^\circ$$

If we now apply KVL to the loop on the left of the network, we obtain

$$-12 + I_1(2 - j1) + (I_1 - I_2)(4 + j2) = 0$$

These two equations will yield the currents. Substituting the first equation into the second yields

$$-12 + I_1(2 - j1 + 4 + j2) - 2(4 + j2) = 0$$

and then

$$I_1 = \frac{20 + j4}{6 + j1} = 3.35 \angle 1.85^\circ \text{ A}$$

Finally,

$$\begin{aligned} V_o &= 4(I_1 - I_2) \\ &= 4\left(\frac{20 + j4}{6 + j1} - 2\right) \\ &= 5.42 \angle 4.57^\circ \text{ V} \end{aligned}$$

(b) In applying superposition to this problem, we consider each source acting alone. If we zero the current source, i.e., replace it with an open circuit, the circuit we obtain is shown in Fig. S8.4(b).

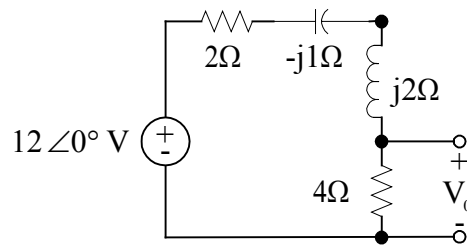

Fig. S8.4(b)

Using voltage division

$$\begin{aligned} V'_o &= 12 \left(\frac{4}{4 + j2 + 2 - j1} \right) \\ &= \frac{48}{6 + j1} \text{ V} \end{aligned}$$

Now, if we zero the voltage source, i.e., replace it with a short circuit, we obtain the circuit in Fig. S8.4(c).

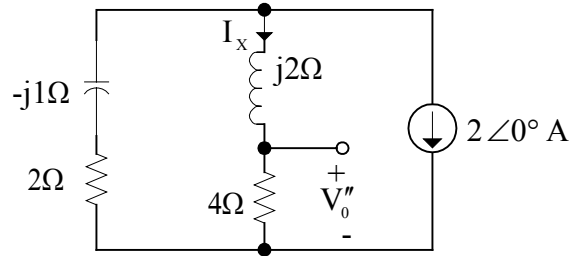

Fig. S8.4(c)

Employing current division, the current I_x is

$$\begin{aligned} I_x &= -2\angle 0^\circ \left(\frac{2-j}{2-j+4+j2} \right) \\ &= \frac{-4+j2}{6+j1} \text{ A} \end{aligned}$$

Then,

$$V_0'' = 4I_x = \frac{-16+j8}{6+j1}$$

And finally,

$$\begin{aligned} V_0 &= V_0' + V_0'' \\ &= \frac{48}{6+j1} + \frac{-16+j8}{6+j1} \\ &= \frac{32+j8}{6+j1} \\ &= 5.42\angle 4.57^\circ \text{ V} \end{aligned}$$

(c) In applying Thevenin's Theorem, we first break the network at the load and determine the open-circuit voltage as shown in Fig. S8.4(d).

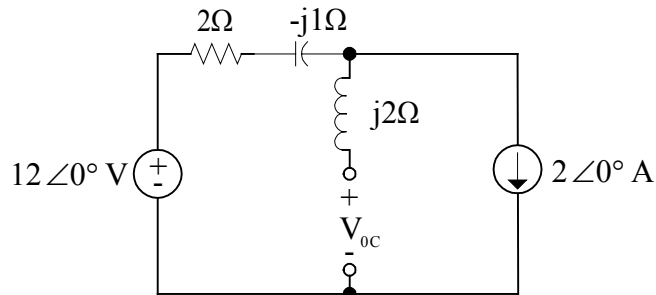

Fig. S8.4(d)

Note that there exists only one closed path and the current in it must be $2\angle 0^\circ$ A. Note also that there is no current in the inductor and therefore no voltage across it. Hence V_{oc} is also the voltage across the current source. Hence,

$$\begin{aligned} V_{oc} &= 12 - 2(2 - j) \\ &= 8 + j2 \text{ V} \end{aligned}$$

The Thevenin equivalent impedance found by zeroing the independent sources and looking into the network at the terminals of the load can be determined from the circuit in Fig. S8.4(e).

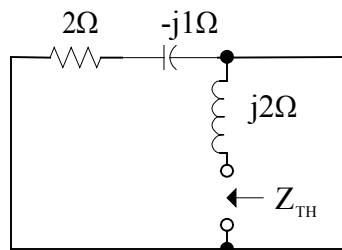

Fig. S8.4(e)

This network indicates that

$$\begin{aligned} Z_{TH} &= 2 - j1 + j2 \\ &= 2 + j1\Omega \end{aligned}$$

If we now form the Thevenin equivalent circuit and re-connect the load, we obtain the network in Fig. S8.4(f).

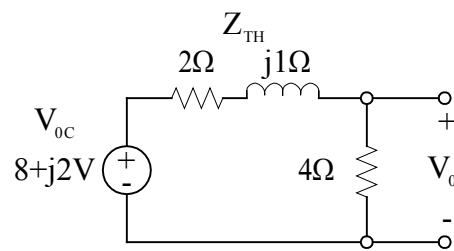

Fig. S8.4(f)

Applying voltage division yields

$$\begin{aligned} V_o &= (8 + j2) \left(\frac{4}{4 + 2 + j1} \right) \\ &= \frac{32 + j8}{6 + j1} \\ &= 5.42 \angle 4.57^\circ \text{ V} \end{aligned}$$

CHAPTER 9 PROBLEMS

- 9.1 Determine the average power supplied by each source in the circuit in Fig. 9.1.

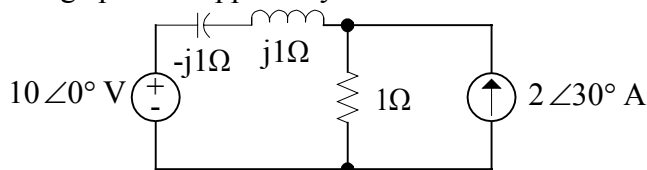

Fig. 9.1

- 9.2 Given the circuit in Fig. 9.2, determine the impedance Z_L for maximum average power transfer and the value of the maximum average power transferred to this load.

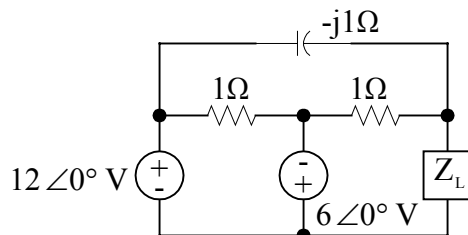

Fig. 9.2

- 9.3 Calculate the rms value of the waveform shown in Fig. 9.3.

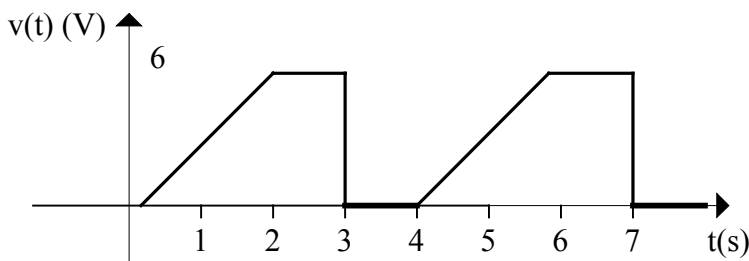

Fig. 9.3

- 9.4 Determine the source voltage in the network shown in Fig. 9.4.

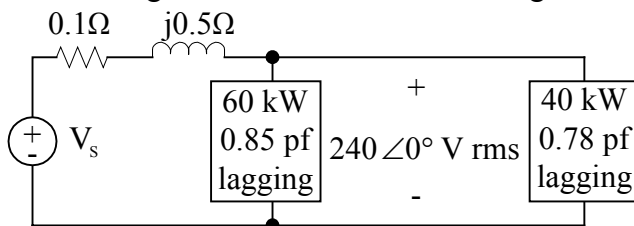

Fig. 9.4

- 9.5 A plant consumes 75 kW at a power factor of 0.70 lagging from a 240-V rms 60 Hz line. Determine the value of the capacitor that when placed in parallel with the load will change the load power factor to 0.9 lagging.

CHAPTER 9 SOLUTIONS

- 9.1 Because the series impedance of the inductor and capacitor are equal in magnitude and opposite in sign, from the standpoint of calculating average power the network can be reduced to that shown in Fig. S9.1.

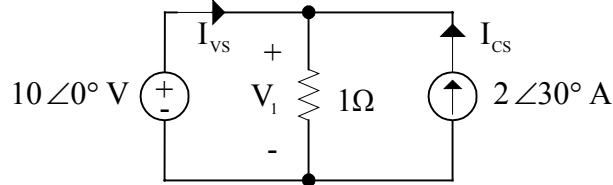

Fig. S9.1

The general expression for average power is

$$P = \frac{1}{2} VI \cos(\theta_v - \theta_i)$$

In the case of the current source $V_1 = 10\text{V}$, $I_{CS} = 2\text{A}$, $\theta_v = 0^\circ$ and $\theta_i = 30^\circ$. Therefore, the average power delivered by the current source is

$$\begin{aligned} P_{CS} &= \left(\frac{1}{2}\right)(10)(2) \cos(-30^\circ) \\ &= 8.66 \text{ W} \end{aligned}$$

In order to calculate the average power delivered by the voltage source, we need the current I_{VS} . Using KCL

$$I_{VS} + 2\angle 30^\circ = \frac{V}{1} = 10\angle 0^\circ$$

or

$$I_{VS} = 8.33\angle -6.9^\circ \text{ A}$$

Now

$$\begin{aligned} P_{VS} &= \frac{1}{2} (10)(8.33) \cos(0^\circ - (-6.9^\circ)) \\ &= 41.34 \text{ W} \end{aligned}$$

Therefore, the total power generated in the network is

$$\begin{aligned} P_T &= P_{CS} + P_{VS} \\ &= 50 \text{ W} \end{aligned}$$

Let us now calculate the average power absorbed by the resistor. We know that the average power absorbed by the resistor must be

$$\begin{aligned} P_R &= \frac{1}{2} \frac{V_m^2}{R} \\ &= \frac{1}{2} \left(\frac{10^2}{1} \right) \\ &= 50 \text{ W} \end{aligned}$$

In addition, the average power absorbed by the resistor can also be determined by

$$P_R = \frac{1}{2} I_m^2 R$$

However, we do not know the current in the resistor. Using KCL.

$$\begin{aligned} I_R &= I_{VS} + I_{CS} \\ &= 8.66 \angle -6.9^\circ + 2 \angle 30^\circ \\ &= 10 \angle 0^\circ \text{ A} \end{aligned}$$

Now

$$\begin{aligned} P_R &= \frac{1}{2} (10)^2 (1) \\ &= 50 \text{ W} \end{aligned}$$

Thus, we find that the total average power generated is equal to the average power absorbed.

- 9.2 We will first determine the Thevenin equivalent circuit for the network without the load attached. The open-circuit voltage, V_{oc} , can be determined from the network in Fig. S9.2(a).

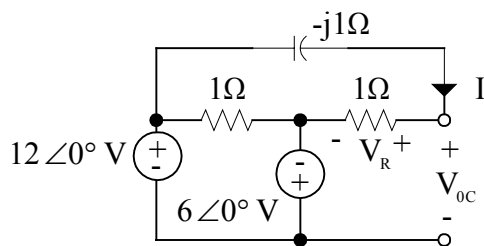

Fig. S9.2(a)

This open-circuit voltage can be calculated in a number of ways. For example, we can compute the current I as

$$I = \frac{12(0^\circ - (-6\angle 0^\circ))}{1 - j} = \frac{18}{1 - j} \text{ A}$$

Then using KVL,

$$\begin{aligned} V_{oc} &= 1I - 6\angle 0^\circ \\ &= \frac{12 + 6j}{1 - j} \text{ V} \end{aligned}$$

or, we could use voltage division to determine the voltage across the 1-Ohm resistor on the right, i.e.,

$$\begin{aligned} V_R &= [12\angle 0^\circ - (-6\angle 0^\circ)] \left(\frac{1}{1 - j} \right) \\ &= \frac{18}{1 - j} \text{ V} \end{aligned}$$

Then, once again

$$\begin{aligned} V_{oc} &= V_R - 6\angle 0^\circ \\ &= \frac{12 + 6j}{1 - j} \text{ V} \\ &= 9.49\angle 71.56^\circ \text{ V} \end{aligned}$$

The Thevenin equivalent impedance is obtained by looking into the open-circuit terminals with all sources made zero. In this case, we replace the voltage sources with short circuits. This network is shown in Fig. S9.2(b).

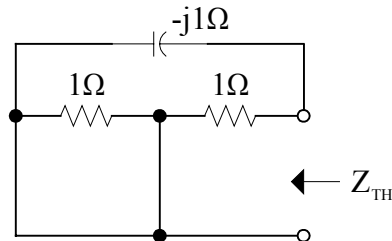

Fig. S9.2(b)

Note that the 1-Ohm resistor on the left is shorted and thus the Z_{TH} is

$$\begin{aligned} Z_{TH} &= \frac{(1)(-j)}{1 - j} = \frac{-j}{1 - j} \Omega \\ &= \frac{1}{2} - j\frac{1}{2} \Omega \end{aligned}$$

Hence, for maximum average power transfer

$$Z_L = Z_{TH}^*$$

or

$$Z_L = \frac{1}{2} + j\frac{1}{2}\Omega$$

Therefore, the network is reduced to that shown in Fig. S9.2(c).

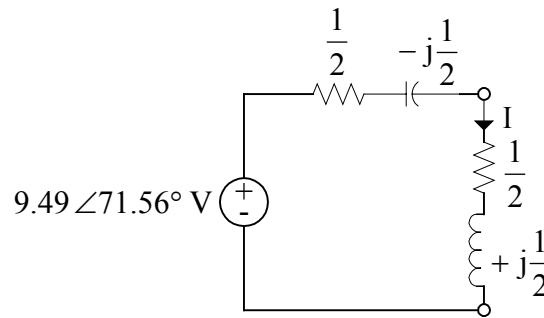

Fig. S9.2(c)

Then

$$\begin{aligned} I &= \frac{9.49 \angle 71.56^\circ}{\frac{1}{2} - j\frac{1}{2} + \frac{1}{2} + j\frac{1}{2}} \\ &= 9.49 \angle 71.56^\circ \text{ A} \end{aligned}$$

and the maximum average power transferred to the load is

$$\begin{aligned} P_L &= \frac{1}{2}(9.49)^2 \left(\frac{1}{2}\right) \\ &= 90 \text{ W} \end{aligned}$$

- 9.3 In order to calculate the rms value of the waveform, we need the equations for the waveform within each of the distinctive intervals.

In the interval $0 \leq t \leq 2s$, the waveform is a straight line that passes through the origin of the graph. The equation for a straight line in this graph is

$$v(t) = mt + b$$

Where m is the slope of the line and b is the $v(t)$ intercept. Since the line goes through the origin, $b = 0$. The slope m is

$$m = \frac{6V}{2s} = 3$$

Therefore, in the interval $0 \leq t \leq 2s$,

$$v(t) = 3t$$

The waveform has constant values in the intervals $2 \leq t \leq 3s$ and $3 \leq t \leq 4s$, i.e.,

$$\begin{aligned} v(t) &= 6 & 2 \leq t \leq 3s \\ v(t) &= 0 & 3 \leq t \leq 4s \end{aligned}$$

Since the waveform repeats after 4s, the period of the waveform is

$$T = 4s$$

Now that the data for the waveform is known,

$$V_{\text{rms}} = \left[\frac{1}{T} \int_0^T v^2(t) dt \right]^{\frac{1}{2}}$$

Therefore, in this case

$$\begin{aligned} V_{\text{rms}} &= \left[\frac{1}{4} \left[\int_0^2 (3t)^2 dt + \int_2^3 (6)^2 dt + \int_3^4 (0)^2 dt \right] \right]^{\frac{1}{2}} \\ &= \left[\frac{1}{4} \left[3t^3 \Big|_0^2 + 36t \Big|_2^3 \right] \right]^{\frac{1}{2}} \\ &= \left[\frac{1}{4} (24 + 36) \right]^{\frac{1}{2}} \\ &= (15)^{\frac{1}{2}} \\ &= 3.87 \text{ V rms} \end{aligned}$$

- 9.4 We begin our analysis by labeling the various currents and voltages in the circuit as shown in Fig. S9.4.

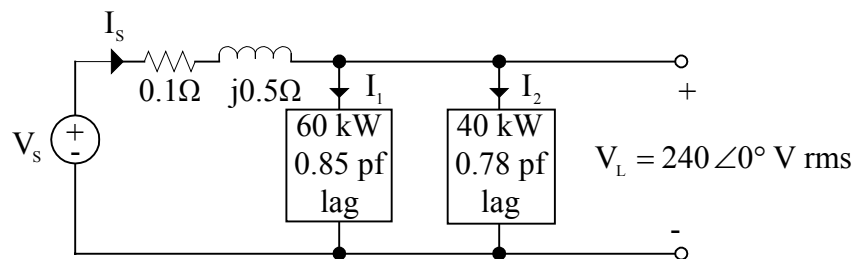

Fig. S9.4

Our approach to determining V_S is straight forward: We will compute the currents I_1 and I_2 ; add them using KCL to find I_S ; determine the voltage across the line impedance and finally use KVL to add the line voltage and load voltage to determine the source voltage.

The magnitude of the current I_1 is

$$\begin{aligned} |I_1| &= \frac{P_1}{|V_L|(\text{pf}_1)} \\ &= \frac{60,000}{(240)(0.85)} \\ &= 294.12 \text{ A rms.} \end{aligned}$$

And the phase angle is

$$\begin{aligned} \theta_{I_1} &= -\cos^{-1}(0.85) \\ &= -31.79^\circ \end{aligned}$$

The negative sign is a result of the fact that the power factor is lagging.

Thus

$$I_1 = 294.12 \angle -31.79^\circ \text{ A rms.}$$

The magnitude of the current I_2 is

$$\begin{aligned} |I_2| &= \frac{P_2}{|V_L|(\text{pf}_2)} \\ &= \frac{40,000}{(240)(0.78)} \\ &= 213.68 \text{ A rms.} \end{aligned}$$

And the phase angle is

$$\begin{aligned} \theta_{I_2} &= -\cos^{-1}(0.78) \\ &= -38.74^\circ \end{aligned}$$

Thus

$$I_2 = 213.68 \angle -38.74^\circ \text{ A rms.}$$

Using KCL

$$\begin{aligned}
 I_s &= I_1 + I_2 \\
 &= 294.12 \angle -31.79^\circ + 213.68 \angle -38.74^\circ \\
 &= 504.1 \angle -34.25^\circ \text{ A rms.}
 \end{aligned}$$

Then

$$\begin{aligned}
 V_2 &= I_s (0.1 + j0.5) + 240 \angle 0^\circ \\
 &= (504.1 \angle -34.25^\circ)(0.51 \angle 78.7^\circ) + 240 \angle 0^\circ \\
 &= 257.04 \angle 44.44^\circ + 240 \angle 0^\circ \\
 &= 460.17 \angle 23.02^\circ \text{ V rms.}
 \end{aligned}$$

9.5 Since the original power factor is 0.7 lagging the power factor angle is

$$\begin{aligned}
 \theta_{\text{OLD}} &= \cos^{-1}(0.7) \\
 &= 45.57^\circ
 \end{aligned}$$

Then

$$\begin{aligned}
 Q_{\text{OLD}} &= P_{\text{OLD}} \tan \theta_{\text{OLD}} \\
 &= 75,000 \tan 45.57^\circ \\
 &= 76.52 \text{ kvar}
 \end{aligned}$$

Hence

$$\begin{aligned}
 S_{\text{OLD}} &= 75,000 + j76,515 \\
 &= 107.14 \angle 45.57^\circ \text{ kVA}
 \end{aligned}$$

The new power factor angle we wish to achieve is

$$\begin{aligned}
 \theta_{\text{NEW}} &= \cos^{-1}(\text{new power factor}) \\
 &= \cos^{-1}(0.9) \\
 &= 25.84^\circ
 \end{aligned}$$

Then

$$\begin{aligned}
 Q_{\text{NEW}} &= P_{\text{OLD}} \tan \theta_{\text{NEW}} \\
 &= 75,000 \tan 25.84^\circ \\
 &= 36,324 \text{ kvar}
 \end{aligned}$$

Now the difference between Q_{NEW} and Q_{OLD} is achieved by the capacitor, i.e.,

$$\begin{aligned}
 Q_{\text{CAP}} &= Q_{\text{NEW}} - Q_{\text{OLD}} \\
 &= 36,324 - 76,515 \\
 &= -40,191 \text{ kvar}
 \end{aligned}$$

And since

$$Q_{CAP} = -\omega CV^2$$

Then

$$\begin{aligned} C &= \frac{40,191}{(377)(240)^2} \\ &= 1850.8 \mu\text{F} \end{aligned}$$

CHAPTER 10 PROBLEMS

- 10.1 Find V_0 in the network in Fig. 10.1.

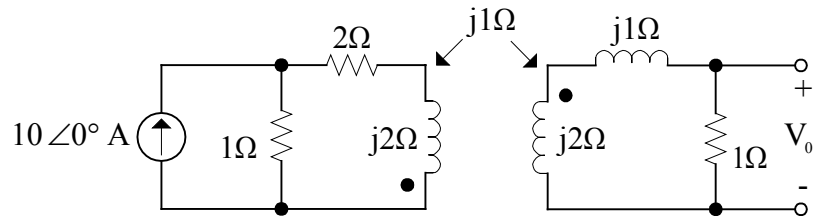

Fig. 10.1

- 10.2 Determine the impedance seen by the source in the circuit in Fig. 10.2.

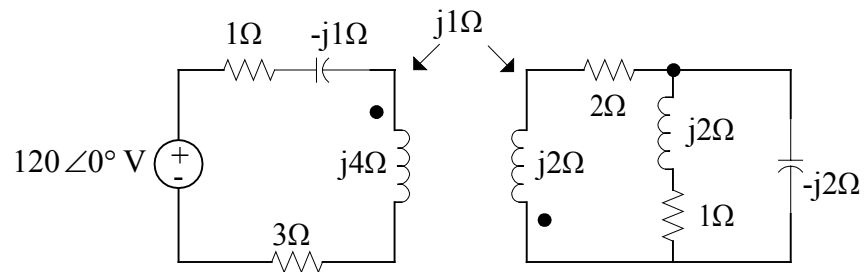

Fig. 10.2

- 10.3 Determine I_1 , I_2 , V_1 and V_2 in the circuit in Fig. 10.3.

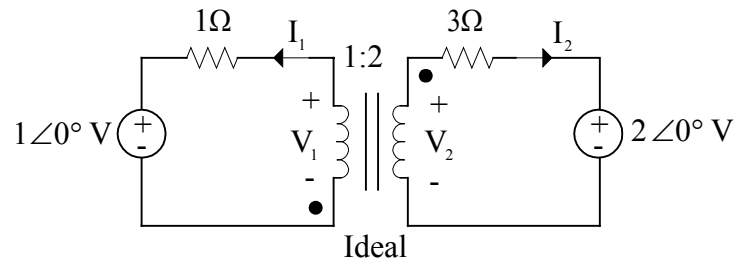

Fig. 10.3

- 10.4 Given the circuit in Fig. 10.3, determine the two networks obtained by replacing (a) the primary and the ideal transformer with an equivalent circuit and (b) the ideal transformer and the secondary with an equivalent circuit.

CHAPTER 10 SOLUTIONS

- 10.1 Our first step in the solution of this problem is to apply source transformation to the left-end of the network and transform the $10\angle 0^\circ$ A source in parallel with the 1Ω resistor into a $10\angle 0^\circ$ V source in series with the 1Ω resistor as shown in Fig. S10.1(a).

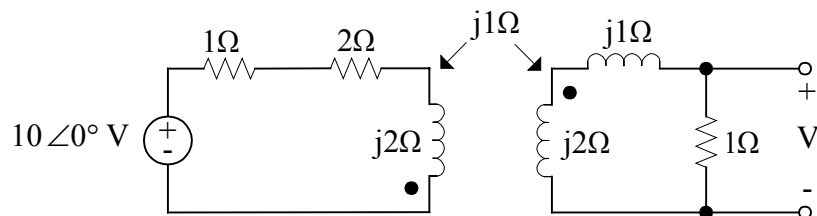

Fig. S10.1(a)

Let us redraw the network as shown in Fig. S10.1(b).

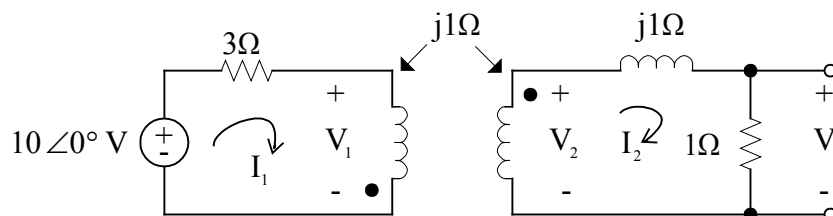

Fig. S10.1(b)

The equations for this network are

$$\begin{aligned} -10 + 3I_1 + V_1 &= 0 \\ -V_2 + I_2(1 + j1) &= 0 \end{aligned}$$

We now write the equations for the mutually coupled coils. In order to force the variables in this circuit into our standard form for mutually coupled inductors, we must reverse the signs on V_1 , I_1 and I_2 . Therefore, the equations that relate V_1 and V_2 to I_1 and I_2 , in this case, are

$$\begin{aligned} -V_1 &= j2(-I_1) + j1(-I_2) \\ V_2 &= j2(-I_2) + j1(-I_1) \end{aligned}$$

Combining the equations yields

$$\begin{aligned} (3 + j2) I_1 + j1 I_2 &= 10 \\ j1 I_1 + (1 + j3) I_2 &= 0 \end{aligned}$$

Solving for I_1 in the second equation and substituting it into the first equation yields

$$[(3 + j2)(-3 + j1) + j1] I_2 = 10$$

or

$$\begin{aligned} I_2 &= \frac{10}{-11 - j2} \\ &= -0.894 \angle 10.3^\circ \text{ A} \end{aligned}$$

And finally

$$\begin{aligned} V_0 &= 1I_2 \\ &= -0.894 \angle 10.3^\circ \text{ V} \end{aligned}$$

- 10.2 Let us first determine the total impedance on the right side of the circuit as shown in Fig. S10.2(a).

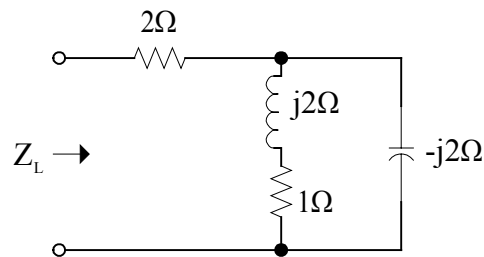

Fig. S10.2(a)

As the figure indicates

$$\begin{aligned} Z_L &= 2 + (1 + j2) \parallel (-j2) \\ &= 2 + \frac{(1 + j2)(-j2)}{1 + j2 - j2} \\ &= 6 - j2\Omega \end{aligned}$$

The original network can now be redrawn in the following form shown in Fig. S10.2(b).

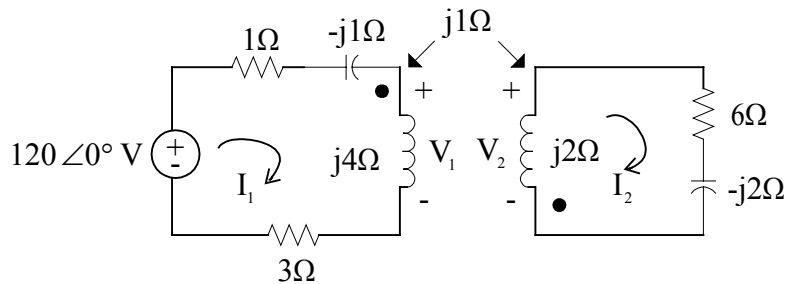

Fig. S10.2(b)

The two KVL equations for the network in Fig. S10.2(b) are

$$\begin{aligned} 120 &= (4 - j1) I_1 + V_1 \\ V_2 &= (6 - j2) I_2 \end{aligned}$$

In order to force the variables in this circuit into our standard form for mutually coupled inductors, we must reverse the sign on V_2 . Therefore, the equations that relate V_1 and V_2 to I_1 and I_2 , in this particular case, are

$$\begin{aligned} V_1 &= j4 I_1 + j1 I_2 \\ -V_2 &= j2 I_2 + j1 I_1 \end{aligned}$$

Combining all of these equations results in the following two equations.

$$\begin{aligned} (4 + j3) I_1 + j1 I_2 &= 120 \\ j1 I_1 + 6 I_2 &= 0 \end{aligned}$$

Solving the second equation for I_2 and substituting this value into the first equation yields

$$\left(4 + j3 + \frac{1}{6}\right) I_1 = 120$$

Then, the impedance seen by the source is

$$Z_s = \frac{120}{I_1} = 4.167 + j3\Omega$$

10.3 The KVL equations for this network are

$$\begin{aligned} 1\angle 0^\circ &= -I_1(1) + V_1 \\ V_2 &= 3I_2 + 2\angle 0^\circ \end{aligned}$$

If we now force the variables in this circuit into our standard form for the ideal transformer, we must reverse the signs on V_1 and I_2 . Therefore, the equations that relate V_1 to V_2 and I_1 to I_2 , in this particular case, are

$$\begin{aligned} \frac{-V_1}{V_2} &= \frac{1}{2} \\ 1I_1 + 2(-I_2) &= 0 \end{aligned}$$

Solving the later equations for V_2 and I_2 and substituting these values into the first equations yields

$$\begin{aligned} 1 &= -I_1 + V_1 \\ -2V_1 &= \frac{3}{2}I_1 + 2 \end{aligned}$$

Solving these equations produces

$$I_1 = 1.142 \angle 180^\circ \text{ A}$$

$$V_1 = 0.142 \angle 180^\circ \text{ V}$$

Then, the transformer relationships yield

$$I_2 = \frac{1}{2} I_1$$

$$V_2 = -2V_1$$

Therefore,

$$I_2 = 0.571 \angle 180^\circ \text{ A}$$

$$V_2 = 0.284 \angle 0^\circ \text{ V}$$

10.4 As shown in the previous problem, the ideal transformer equations are

$$\frac{-V_1}{V_2} = \frac{1}{2}$$

$$1I_1 + 2(I_2) = 0$$

These two equations and the equation for reflecting impedance from the primary of the transformer to the secondary i.e.,

$$Z_p = \left(\frac{N_1}{N_2} \right)^2 Z_s$$

$$= \frac{1}{4} Z_s$$

are the necessary equations for developing the equivalent circuits.

(a) If we reflect the primary to the secondary, we note that

$$V_2 = -2V_1$$

And

$$Z_s = 4Z_p$$

Therefore, the voltage source in the primary becomes

$$V_2 = -2(1 \angle 0^\circ)$$

$$= 2 \angle 180^\circ \text{ V}$$

And

$$\begin{aligned} Z_S &= 4(1) \\ &= 4\Omega \end{aligned}$$

Therefore, the equivalent circuit in this case is shown in Fig. S10.4(a).

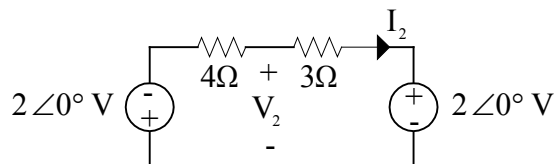

Fig. S10.4(a)

(b) Once again, using the ideal transformer equation to reflect the secondary to the primary we obtain the network in Fig. S10.4(b).

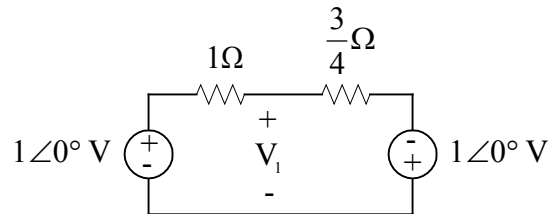

Fig. S10.4(b)

CHAPTER 11 PROBLEMS

- 11.1 In a three-phase balanced wye-wye system, the source is an abc-sequence set of voltages with $V_{an} = 120\angle 40^\circ$ V rms. The per phase impedance of the load is $10 + j8\Omega$. If the line impedance per phase is $0.6 + j0.4\Omega$, find the line currents and load voltages.
- 11.2 An abc-sequence set of voltages feeds a balanced three-phase wye-wye system. If $V_{an} = 440\angle 40^\circ$ V rms, $V_{AN} = 410\angle 39^\circ$ V rms and the line impedance is $1.5 + j1.0\Omega$, find the load impedance.
- 11.3 In a balanced three-phase wye-delta system, the source has an abc-phase sequence and $V_{an} = 120\angle 30^\circ$ V rms. The line and load impedance are $0.6 + j0.4\Omega$ and $24 + j12\Omega$, respectively. Find the delta currents in the load.
- 11.4 A balanced three-phase source serves two loads:
Load 1: 32 kVA at 0.85 pf lagging.
Load 2: 20 kVA at 0.6 pf lagging.
The line voltage at the load is 208 V rms at 60Hz. Determine the line current and the combined power factor at the load.
- 11.5 In a three-phase balanced system an abc-sequence wye-connected source with $V_{an} = 220\angle 0^\circ$ V rms supplies power to a wye-connected load that consumes 36 kW of power in each phase at a pf of 0.75 lagging. Three capacitors, each with an impedance of $-j2.0\Omega$, are connected in parallel with the original load in a wye configuration. Determine the power factor of the combined load as seen by the source.

CHAPTER 11 SOLUTIONS

- 11.1 First of all, we note that since this is a balanced system, we need only consider one phase of the system. All currents in the two remaining phases have the same magnitude but are shifted in phase by 120° and 240° .

Consider now the circuit for the a-phase shown in Fig. S11.1.

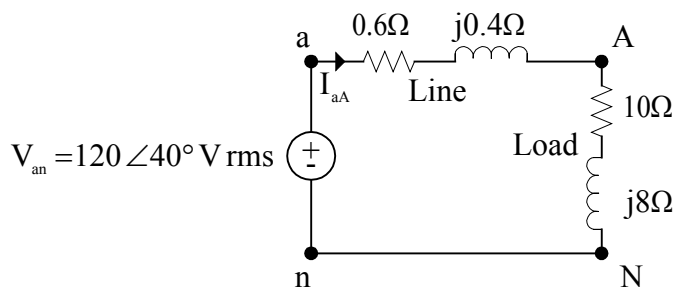

Fig. S11.1

In this circuit, lower case letters represent the source end of the network and capital letters represent the load end of the network. The line current for this a-phase is

$$\begin{aligned} I_{aA} &= \frac{V_{an}}{Z_{\text{Line}} + Z_{\text{Load}}} \\ &= \frac{120 \angle 40^\circ}{10.6 + j8.4} \\ &= 8.87 \angle 1.6^\circ \text{ A rms.} \end{aligned}$$

Then the load voltage for this phase is

$$\begin{aligned} V_{AN} &= I_{aA} Z_{\text{Load}} \\ &= (8.87 \angle 1.6^\circ)(10 + j8) \\ &= 113.59 \angle 40.26^\circ \text{ V rms.} \end{aligned}$$

The results for the two remaining phases are

$$\begin{aligned} I_{bB} &= 8.87 \angle -118.4^\circ \text{ A rms} & V_{BN} &= 113.59 \angle -79.74^\circ \text{ V rms} \\ I_{cC} &= 8.87 \angle -238.4^\circ \text{ A rms} & V_{CN} &= 113.59 \angle -199.74^\circ \text{ V rms.} \end{aligned}$$

- 11.2 The a-phase equivalent circuit for this system is shown in Fig. S10.2.

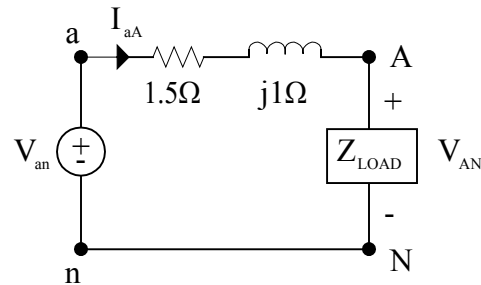

Fig. S11.2

We can approach this problem in a couple of ways. For example, note that by employing voltage division, we can write

$$V_{AN} = V_{an} \left[\frac{Z_{Load}}{Z_{Load} + Z_{Line}} \right]$$

If we solve this equation for Z_{Load} , we obtain

$$Z_{Load} = \frac{Z_{Line}}{\frac{V_{an}}{V_{AN}} - 1}$$

where the quantities on the right side of the equation are all given.

We can also calculate the line current I_{aA} and use it with V_{AN} to determine Z_{Load} . In this later case

$$\begin{aligned} I_{aA} &= \frac{V_{an} - V_{AN}}{1.5 + j1} \\ &= 17.15 \angle 19.6^\circ \text{ A rms} \end{aligned}$$

Then

$$\begin{aligned} Z_{Load} &= \frac{V_{AN}}{I_{aA}} \\ &= \frac{410 \angle 39^\circ}{17.15 \angle 19.6^\circ} \\ &= 23.91 \angle 19.4^\circ \Omega \end{aligned}$$

11.3 To begin we convert the delta load to an equivalent wye. In this balanced case

$$\begin{aligned} Z_Y &= \frac{Z_\Delta}{3} \\ &= 8 + j4\Omega \end{aligned}$$

Now the a-phase wye-wye circuit is shown in Fig. S11.3.

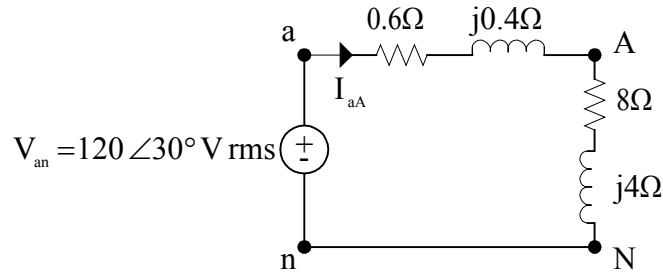

Fig. S11.3

Now the line current for this network is

$$\begin{aligned} I_{aA} &= \frac{120 \angle 30^\circ}{8.6 + j4.4} \\ &= 12.42 \angle 2.9^\circ \text{ A rms} \end{aligned}$$

This is the current in the a-phase of an equivalent wye load. We can now convert this current to the AB phase of the delta.

$$I_{AB} = \frac{|I_{aA}|}{\sqrt{3}} \angle \theta_{I_{aA}} + 30^\circ$$

Therefore

$$I_{AB} = 7.17 \angle 32.9^\circ \text{ A rms}$$

The currents in the remaining phases of the delta are

$$I_{BC} = 7.17 \angle -87.1^\circ \text{ A rms and } I_{CA} = 7.17 \angle -207.1^\circ \text{ A rms.}$$

11.4 The total complex power at the load is

$$\begin{aligned} S_{L3\phi} &= 32 \angle \cos^{-1}(0.85) + 20 \angle \cos^{-1}(0.6) \text{ kVA} \\ &= 32 \angle 31.79^\circ + 20 \angle 53.13^\circ \text{ kVA} \\ &= 51.15 \angle 39.97^\circ \text{ kVA} \end{aligned}$$

Now, we know that

$$|S_{L3\phi}| = \sqrt{3} V_L I_L$$

And hence

$$\begin{aligned} I_L &= \frac{51.15\text{k}}{\sqrt{3} (208)} \\ &= 141.98 \text{ A rms} \end{aligned}$$

And the power factor at the load is

$$\begin{aligned} \text{pf}_{\text{Load}} &= \cos(39.97^\circ) \\ &= 0.766 \text{ lagging} \end{aligned}$$

11.5 The original situation, prior to adding the capacitors is

$$P_{\text{OLD}} = 36 \text{ kW}$$

$$\begin{aligned} Q_{\text{OLD}} &= P_{\text{OLD}} \tan \theta_{\text{OLD}} \\ &= 36,000 \tan 41.41^\circ \\ &= 31,749 \text{ var} \end{aligned}$$

where $41.41^\circ = \theta_{\text{OLD}} = \cos^{-1}(0.75)$. Therefore,

$$S_{\text{OLD}} = 36 + j31.749 \text{ kVA}$$

is the complex power for each phase.

If we now add the capacitor, the real power is unaffected by this and thus

$$P_{\text{NEW}} = P_{\text{OLD}} = 36 \text{ kW}$$

However,

$$Q_{\text{NEW}} = Q_{\text{OLD}} + Q_C$$

Where Q_C is the reactive power supplied by the capacitor.

$$\begin{aligned} Q_C &= -j\omega C V^2 \text{ rms} \\ &= \frac{-V^2 \text{ rms}}{|Z_C|} \end{aligned}$$

or

$$\begin{aligned} Q_c &= \frac{-(220)^2}{2} \\ &= -24.2 \text{ k var} \end{aligned}$$

Therefore,

$$\begin{aligned} Q_{\text{NEW}} &= 31.79 - 24.2 \\ &= 7.59 \text{ kvar} \end{aligned}$$

And hence

$$\begin{aligned} S_{\text{NEW}} &= P_{\text{NEW}} + jQ_{\text{NEW}} \\ &= 36 + j7.59 \\ &= 36.79 \angle 11.9^\circ \text{ kVA} \end{aligned}$$

And

$$\begin{aligned} \text{Pf}_{\text{NEW}} &= \cos \theta_{\text{NEW}} \\ &= \cos 11.9^\circ \\ &= 0.98 \text{ lagging} \end{aligned}$$

CHAPTER 12 PROBLEMS

- 12.1 Sketch the bode plot for the following network function

$$H(j\omega) = \frac{36(0.5j\omega + 1)}{(j\omega)^2(0.02j\omega + 1)}$$

- 12.2 Sketch the bode plot for the following network function

$$H(j\omega) = \frac{250j\omega(j\omega + 10)}{(j\omega + 1)(j\omega + 50)(j\omega + 100)}$$

- 12.3 Given the magnitude characteristic for the network function shown in Fig. 12.3, find the expression for $H(j\omega)$

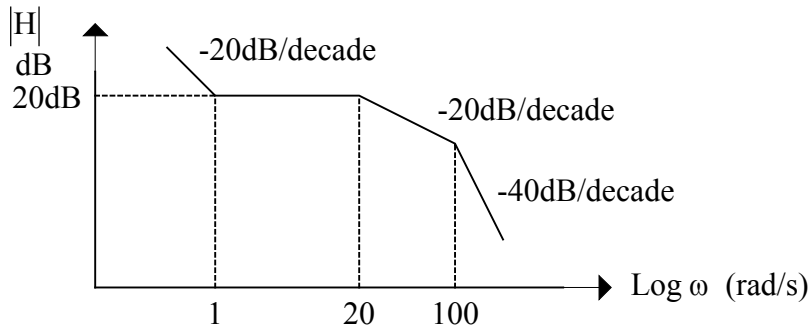

Fig. 12.3

- 12.4 Given the series circuit shown in Fig. 12.4, determine the following parameters: ω_0 , Q and the BW. If the resistance is changed to 0.1Ω , what is the impact on these parameters.

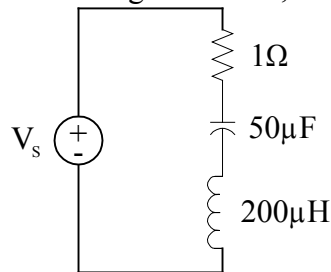

Fig. 12.4

Sketch the frequency characteristic for the two values of R . What conclusion can be drawn from these two characteristics.

- 12.5 The network in Fig. 12.5 operates as a band pass filter. (a) Determine the transfer function for the network, (b) find the upper and lower cut off frequencies and the band width and (c) sketch the magnitude characteristic for this transfer function.

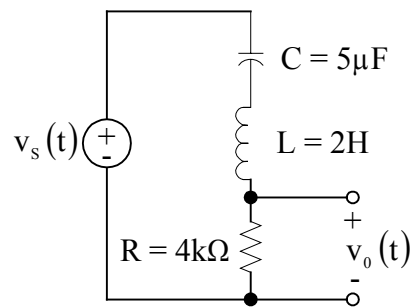

Fig. 12.5

CHAPTER 12 SOLUTIONS

- 12.1 First of all, we note that all the poles and zeros are in the standard form, e.g. the simple pole and zero are each in the form $(j\omega\tau + 1)$. At low frequencies the controlling term is the double pole at the origin. This term provides an initial slope for the magnitude characteristic of -40dB/decade . Furthermore, this initial slope will intersect the 0dB line at $\omega = \sqrt{36} = 6 \text{ rad/s}$. However, before this initial slope intersects the 0dB line, we encounter the break frequency of the zero at $\omega = \frac{1}{\tau} = \frac{1}{0.5} = 2 \text{ rad/s}$. This term adds a slope of $+20\text{dB/decade}$ to the magnitude characteristic and thus the composite characteristic changes from -40dB/decade to -20dB/decade . This characteristic maintains this slope until another break frequency is encountered. The remaining pole has a break frequency at $\omega = \frac{1}{\tau} = \frac{1}{0.02} = 50 \text{ rad/s}$. This term adds a slope of -20dB/decade to the magnitude characteristic, and since there are no more poles or zeros in the network function, the final slope of the magnitude characteristic is -40dB/decade . The composite magnitude characteristic is shown in Fig. S12.1(a).

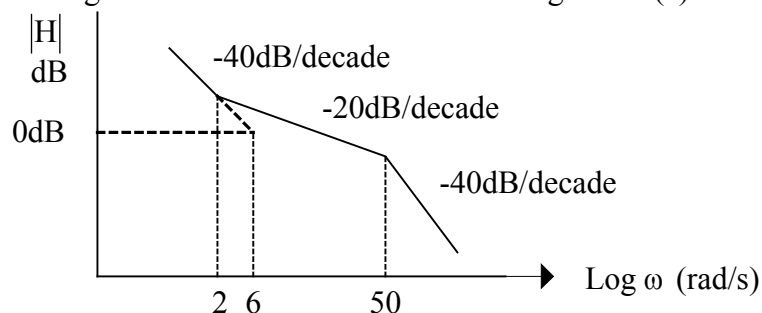

Fig. S12.1(a)

The composite phase characteristic for this network function is shown in Fig. S12.1(b).

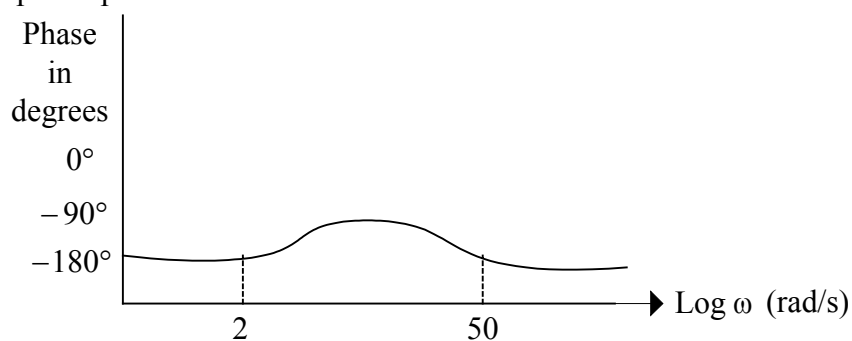

Fig. S12.1(b)

Once again, the initial phase, at low frequencies, is controlled by the double pole at the origin that has a constant phase of -180° . The phase for the zero is an arc tangent curve that provides 45° of phase at the break frequency, $\omega = 2 \text{ rad/s}$. As the frequency increases beyond the break frequency this term provides 90° of phase so the composite curve approaches -90° of phase. As the frequency increases further, we encounter the

simple pole which provides -45° of phase at its break frequency and finally -90° of phase at higher frequencies. Thus the composite phase starts at -180° , moves toward -90° because of the presence of the zero and finally ends up back at -180° because of the last pole.

- 12.2 We begin the analysis by putting all the terms of the network function in standard form. The function then becomes

$$H(j\omega) = \frac{0.5j\omega(0.1j\omega + 1)}{(j\omega + 1)(0.02j\omega + 1)(0.01j\omega + 1)}$$

At low frequencies the magnitude characteristic is controlled by the zero at the origin. This term provides an initial slope of $+20\text{dB/decade}$ and it will intersect the 0dB line at $\omega = \frac{1}{0.5} = 2 \text{ rad/s}$. Prior to reaching this frequency we encounter the break frequency of

the pole $(j\omega + 1)$ which occurs at $\omega = \frac{1}{\tau} = \frac{1}{1} = 1 \text{ rad/s}$. This term adds a slope of $-$

20dB/decade to the magnitude characteristic and therefore the composite characteristic has a net slope of $-20 + 20 = 0\text{dB/decade}$, i.e., the composite characteristic is flat until it encounters another break frequency. The next break frequency is due to the simple zero

with break frequency at $\omega = \frac{1}{0.1} = 10 \text{ rad/s}$. At this point, the composite curve changes slope to $+20\text{dB/decade}$. The remaining two terms in the network function are poles with break frequencies at $\omega = \frac{1}{0.02} = 50 \text{ rad/s}$ and $\omega = \frac{1}{0.01} = 100 \text{ rad/s}$. Since each adds a

slope of -20dB/decade , the composite characteristic shifts from $+20\text{dB/decade}$ to 0dB/decade and then to -20dB/decade . The total composite characteristic is shown in Fig. S12.2(a).

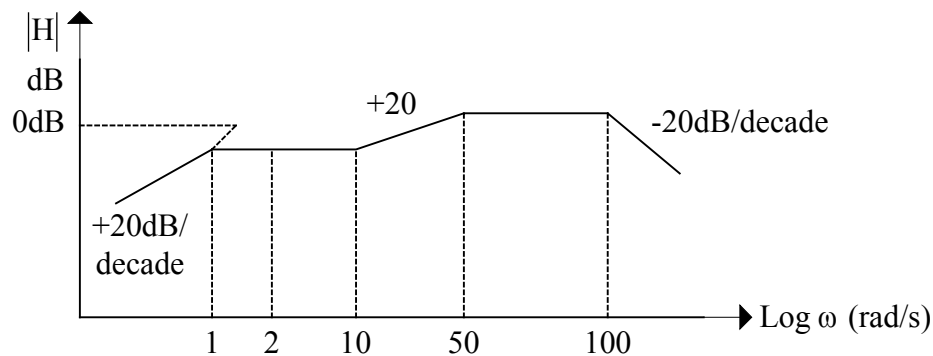

Fig. S12.2(a)

The composite phase characteristic for the network function is shown in Fig. S12.2(b).

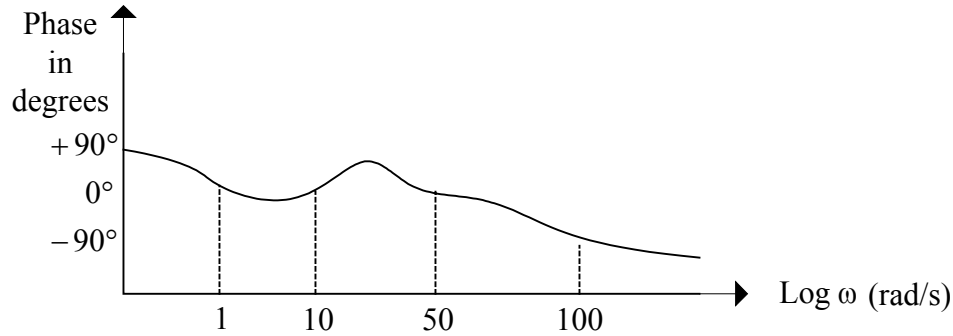

Fig. S12.2(b)

At low frequencies, the initial phase is $+90^\circ$ due to the zero at the origin. The first break frequency encountered is due to the pole term $(j\omega + 1)$ with break frequency at $\omega = 1$ rad/s. Thus the phase shifts toward 0° on an arc tangent curve that provides -45° of phase at $\omega = 1$ rad/s. The phase proceeds toward 0° until it encounters the zero with a break frequency of $\omega = \frac{1}{0.1} = 10$ rad/s. This term shifts the phase toward $+90^\circ$ going through $+45^\circ$ at the break frequency. The two remaining poles shift the composite phase back to 0° and finally to -90° as the characteristic indicates.

- 12.3 Examining the magnitude characteristic we note that at low frequencies the characteristic has an initial slope of -20dB/decade indicating a single pole at the origin. Furthermore, this initial slope passes through the 20dBs at $\omega = 1$ rad/s. Since the slope is -20dB/decade , this initial slope will cross the 0dB line at $\omega = 10$ rad/s. Therefore, the constant term, i.e., gain, in the network function is 10. Since the slope changes at $\omega = 1$ rad/s from -20dB/decade to 0dB/decade , there is a simple zero at this break frequency. At $\omega = 20$ rad/s, the slope changes again. This time the slope shifts from 0dB/decade to -20dB/decade indicating the presence of a simple pole with break frequency $\omega = 20$ rad/s. Finally, there is another simple pole with break frequency $\omega = 100$ rad/s. Therefore, the composite network function is

$$H(j\omega) = \frac{10(j\omega + 1)}{(j\omega)\left(\frac{j\omega}{20} + 1\right)\left(\frac{j\omega}{100} + 1\right)}$$

- 12.4 For this network, the resonant frequency is

$$\begin{aligned}\omega_0 &= \frac{1}{\sqrt{LC}} \\ &= \frac{1}{\sqrt{(200 \times 10^{-6})(50 \times 10^{-6})}} \\ &= 10,000 \text{ rad/s}\end{aligned}$$

The quality factor is

$$\begin{aligned} Q &= \frac{\omega_0 L}{R} \\ &= \frac{(10^4)(200 \times 10^{-6})}{1} \\ &= 2 \end{aligned}$$

And the bandwidth is

$$\begin{aligned} \text{BW} &= \frac{\omega_0}{Q} \\ &= \frac{10^4}{2} \\ &= 5000 \text{ rad/s} \end{aligned}$$

If the resistance, R , is now changed from 1Ω to 0.1Ω the resonant frequency is unaffected. However, the Q changes to

$$\begin{aligned} Q &= \frac{\omega_0 L}{R} \\ &= \frac{(10^4)(200 \times 10^{-6})}{0.1} \\ &= 20 \end{aligned}$$

And the bandwidth is

$$\begin{aligned} \text{BW} &= \frac{\omega_0}{Q} \\ &= \frac{10^4}{20} \\ &= 500 \text{ rad/s} \end{aligned}$$

A sketch of the two frequency characteristics is shown in Fig. S12.4.

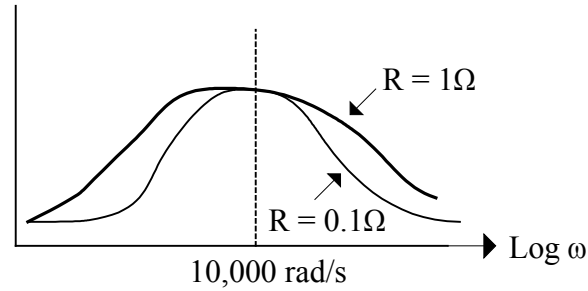

Fig. S12.4

Note that the higher value of Q , i.e., lower value of R , produces a more selective circuit with a much smaller bandwidth.

12.5 (a) Using voltage division, we can express the output as

$$V_o = \left[\frac{R}{R + j\omega L + \frac{1}{j\omega C}} \right] V_s$$

or

$$\frac{V_o}{V_s} = \frac{R}{R + j\left(\omega L - \frac{1}{\omega C}\right)}$$

And therefore

$$\left| \frac{V_o}{V_s} \right| = \frac{RC\omega}{\left[(RC\omega)^2 + \left(\omega^2 LC - 1 \right)^2 \right]^{\frac{1}{2}}}$$

(b) The upper and lower cut off frequencies are the roots of the characteristic equation, i.e., the denominator of the transfer function.

At the lower cut off frequency

$$\omega^2 LC - 1 = -RC\omega$$

or

$$\omega^2 + \frac{R}{L}\omega - \omega_0^2 = 0$$

where, of course, $\omega_0^2 = \frac{1}{LC}$. With the component values, this function becomes

$$\omega^2 + 2000\omega - 10^5 = 0$$

Solving for ω_{LO} , we obtain

$$\begin{aligned}\omega_{LO} &= \frac{-2000 + \sqrt{(2000)^2 + 4 \times 10^5}}{2} \\ &= 48.8 \text{ rad/s}\end{aligned}$$

At the upper cut off frequency

$$\omega^2 LC - 1 = +RC\omega$$

or

$$\omega^2 - \frac{R}{L}\omega - \omega_0^2 = 0$$

and ω_{HI} is

$$\begin{aligned}\omega_{HI} &= \frac{2000 + \sqrt{(2000)^2 + 4 \times 10^5}}{2} \\ &= 2048.8 \text{ rad/s}\end{aligned}$$

Therefore, the bandwidth is

$$\begin{aligned}BW &= \omega_{HI} - \omega_{LO} = \frac{R}{L} \\ &= 2048.8 - 48.8 = \frac{4000}{2} \\ &= 2000 \text{ rad/s}\end{aligned}$$

(c) Since the resonant frequency is

$$\begin{aligned}\omega_0 &= \frac{1}{\sqrt{LC}} \\ &= \frac{1}{\sqrt{2 \times 5 \times 10^{-6}}} \\ &= 316.23 \text{ rad/s}\end{aligned}$$

The magnitude characteristic for the function is shown in Fig. S12.5.

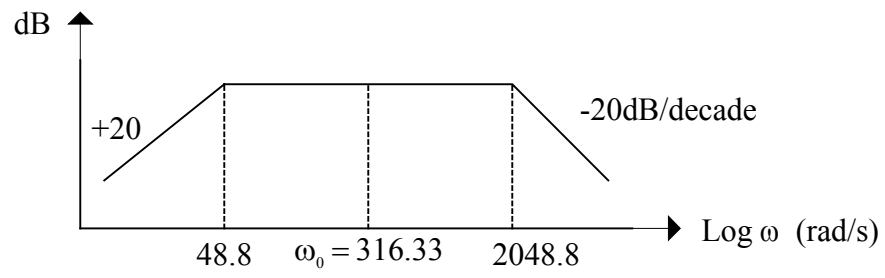

Fig. S12.5

CHAPTER 13 PROBLEMS

13.1 If $f(t) = e^{-at} \sin bt$, find $F(s)$ using (a) the definition of the Laplace Transform and (b) the fact that $L[e^{-at} f(t)] = F(s + a)$.

13.2 Find $f(t)$ if $F(s)$ is given by the expression

$$F(s) = \frac{24s}{(s+2)(s+4)(s+6)}$$

13.3 Find $f(t)$ if $F(s)$ is given by the expression

$$F(s) = \frac{4(s+4)}{s(s^2 + 8s + 20)}$$

13.4 Find $f(t)$ if $F(s)$ is given by the expression

$$F(s) = \frac{12(s+2)}{(s^2 + 2s + 1)(s+3)}$$

13.5 Given the function

$$F(s) = \frac{24(s+10)}{s(s+2)(s+4)}$$

Find the initial and final values of the function by evaluating it in both the s -domain and time domain.

CHAPTER 13 SOLUTIONS

13.1 (a) By definition

$$F(s) = \int_0^{\infty} f(t) e^{-st} dt$$

And since $f(t) = e^{-at} \sin bt$

$$F(s) = \int_0^{\infty} e^{-at} \sin bt e^{-st} dt$$

Using Euler's identity

$$\begin{aligned} F(s) &= \int_0^{\infty} e^{-(s+a)t} \left[\frac{e^{jbt} - e^{-jbt}}{2j} \right] dt \\ &= \int_0^{\infty} \frac{e^{-(s+a-jb)t} - e^{-(s+a+jb)t}}{2j} dt \end{aligned}$$

Evaluating the integral

$$\begin{aligned} &= \frac{1}{2j} \left[\frac{1}{s+a-jb} - \frac{1}{s+a+jb} \right] \\ &= \frac{b}{(s+a)^2 + b^2} \end{aligned}$$

(b) In this case $f(t) = \sin bt$. Then

$$F(s) = \int_0^{\infty} e^{-st} \sin bt dt$$

Again, using the Euler identity

$$\begin{aligned} F(s) &= \int_0^{\infty} e^{-st} \left(\frac{e^{jbt} - e^{-jbt}}{2j} \right) dt \\ &= \frac{1}{2j} \int_0^{\infty} (e^{-(s-jb)t} - e^{-(s+jb)t}) dt \end{aligned}$$

Evaluating the integral

$$\begin{aligned}
 &= \frac{1}{2j} \left[\frac{1}{s - jb} - \frac{1}{s + jb} \right] \\
 &= \frac{b}{s^2 + b^2}
 \end{aligned}$$

Then using the fact that $\mathcal{L}[e^{-at} f(t)] = F(s + a)$ where in this case $f(t) = \sin bt$ and

$$F(s) = \frac{b}{s^2 + b^2}$$

we find that

$$\begin{aligned}
 F(s + a) &= \mathcal{L}[e^{-at} f(t)] \\
 &= \mathcal{L}[e^{-at} \sin bt] \\
 &= \frac{b}{(s + a)^2 + b^2}
 \end{aligned}$$

13.2 The expression

$$F(s) = \frac{24s}{(s + 2)(s + 4)(s + 6)}$$

can be written in a partial fraction expansion of the form

$$\frac{24s}{(s + 2)(s + 4)(s + 6)} = \frac{k_1}{s + 2} + \frac{k_2}{s + 4} + \frac{k_3}{s + 6}$$

Multiplying the entire equation by the term $s + 2$ yields

$$\frac{24s}{(s + 4)(s + 6)} = k_1 + \frac{k_2(s + 2)}{s + 4} + \frac{k_3(s + 2)}{s + 6}$$

If we now evaluate each term at $s = -2$, we find that the last two terms on the right side of the equation vanish and we have

$$\begin{aligned}
 \left. \frac{24s}{(s + 4)(s + 6)} \right|_{s = -2} &= k_1 \\
 -6 &= k_1
 \end{aligned}$$

Repeating this procedure for the two remaining terms in the denominator, i.e., $(s + 4)$ and $(s + 6)$ yields

$$\left. \frac{24s}{(s+2)(s+6)} \right|_{s=-4} = k_2$$

$$24 = k_2$$

And

$$\left. \frac{24s}{(s+2)(s+4)} \right|_{s=-6} = k_3$$

$$-18 = k_3$$

Now the function $F(s)$ can be written in the form

$$F(s) = \frac{-6}{s+2} + \frac{24}{s+4} - \frac{18}{s+6}$$

The reader can check the validity of this expansion by recombining the terms to produce the original expression.

Once $F(s)$ is in this latter form, we can use the transform pair

$$\mathcal{L} [e^{-at}] = \frac{1}{s+a}$$

And hence

$$f(t) = [-6e^{-2t} + 24e^{-4t} - 18e^{-6t}]u(t)$$

- 13.3 We begin by writing the function in a partial fraction expansion. Therefore, we need to know the roots of the quadratic term. We can either employ the quadratic formula or recognize that

$$\begin{aligned} s^2 + 8s + 20 &= s^2 + 8s + 16 + 4 \\ &= (s+4)^2 + 4 \\ &= (s+4-j2)(s+4+j2) \end{aligned}$$

Hence, the function $F(s)$ can be written as

$$F(s) = \frac{4(s+4)}{s(s+4-j2)(s+4+j2)} = \frac{k_0}{s} + \frac{k_1}{s+4-j2} + \frac{k_1^*}{s+4+j2}$$

Multiplying the entire equation by s and evaluating it at $s=0$ yields

$$\left. \frac{4(s+4)}{s^2+8s+20} \right|_{s=0} = k_0$$

$$\frac{4}{5} = k_0$$

Using the same procedure for k_1 , we obtain

$$\left. \frac{4(s+4)}{s(s+4+j2)} \right|_{s=-4+j2} = k_1$$

$$\frac{1}{-2+j} = k_1$$

$$\frac{-1}{2-j} = k_1$$

$$\frac{-(2+j)}{5} = k_1$$

$$\frac{1}{\sqrt{5}} \angle 206.56^\circ = k_1$$

Then, we know that

$$\frac{1}{\sqrt{5}} \angle -206.56^\circ = k_1^*$$

Now using the fact that

$$\mathcal{L} \left[\frac{|k_1| \angle \theta}{s+a-jb} + \frac{|k_1| \angle -\theta}{s+a+jb} \right] = 2|k_1| e^{-at} \cos(bt + \theta)$$

The function $f(t)$ is

$$f(t) = \left[\frac{4}{5} + \frac{2}{\sqrt{5}} e^{-4t} \cos(2t + 206.56^\circ) \right] u(t)$$

- 13.4 In order to perform a partial fraction expansion on the function $F(s)$, we need to factor the quadratic term. We can use the quadratic formula or simply note that $(s+1)(s+1) = s^2 + 2s + 1$. Therefore, $F(s)$ can be expressed as

$$F(s) = \frac{12(s+2)}{(s+1)^2(s+3)}$$

or in the form

$$F(s) = \frac{12(s+2)}{(s+1)^2(s+3)} = \frac{k_{11}}{s+1} + \frac{k_{12}}{(s+1)^2} + \frac{k_2}{s+3}$$

If we now multiply the entire equation by $(s+1)^2$, we obtain

$$\frac{12(s+2)}{s+3} = k_{11}(s+1) + k_{12} + \frac{k_2(s+1)^2}{s+3}$$

Now evaluating this equation at $s = -1$ yields

$$\left. \frac{12(s+2)}{s+3} \right|_{s=-1} = k_{12}$$

$$6 = k_{12}$$

In order to evaluate k_{11} we differentiate each term of the equation with respect to s and evaluate all terms at $s = -1$. Note that the derivative of k_{12} with respect to s is zero, the derivative of the last term in the equation with respect to s will still have an $(s+1)$ term in the numerator that will vanish when evaluated at $s = -1$, and the derivative of the first term on the right side of the equation with respect to s simply yields k_{11} . Therefore,

$$\left. \frac{d}{ds} \left[\frac{12(s+2)}{s+3} \right] \right|_{s=-1} = k_{11}$$

$$\left. \frac{(s+3)(12) - 12(s+2)(1)}{(s+3)^2} \right|_{s=-1} = k_{11}$$

$$3 = k_{11}$$

Finally,

$$\left. \frac{12(s+2)}{(s+1)^2} \right|_{s=-3} = k_2$$

$$-3 = k_2$$

And therefore, $F(s)$ can be expressed in the form

$$F(s) = \frac{3}{s+1} + \frac{6}{(s+1)^2} - \frac{3}{s+2}$$

Using the transform pairs, we find that

$$f(t) = [3e^{-t} + 6te^{-t} - 3e^{-2t}]u(t)$$

13.5 First, let us use the Theorems to evaluate the function in the s-domain.

The initial value can be derived from the Theorem

$$\lim_{t \rightarrow 0} f(t) = \lim_{s \rightarrow \infty} sF(s)$$

Therefore,

$$\begin{aligned} \lim_{s \rightarrow \infty} sF(s) &= \lim_{s \rightarrow \infty} \left[\frac{24(s+10)}{(s+2)(s+4)} \right] \\ &= \lim_{s \rightarrow \infty} \left[\frac{24s + 240}{s^2 + 6s + 8} \right] \\ &= \lim_{s \rightarrow \infty} \left[\frac{\frac{24}{s} + \frac{240}{s^2}}{1 + \frac{6}{s} + \frac{8}{s^2}} \right] \\ &= 0 \end{aligned}$$

The final value is derived from the expression

$$\lim_{t \rightarrow \infty} f(t) = \lim_{s \rightarrow 0} sF(s)$$

Hence,

$$\begin{aligned} \lim_{s \rightarrow 0} sF(s) &= \lim_{s \rightarrow 0} \left[\frac{24(s+10)}{(s+2)(s+4)} \right] \\ &= \frac{240}{8} \\ &= 30 \end{aligned}$$

The time function can be derived from a partial fraction expansion as

$$F(s) = \frac{24(s+10)}{s(s+2)(s+4)} = \frac{k_0}{s} + \frac{k_1}{s+2} + \frac{k_2}{s+4}$$

where

$$\left. \frac{24(s+10)}{(s+2)(s+4)} \right|_{s=0} = k_0 = 30$$

$$\left. \frac{24(s+10)}{s(s+4)} \right|_{s=-2} = k_1 = -48$$

$$\left. \frac{24(s+10)}{s(s+2)} \right|_{s=-4} = k_2 = 18$$

Hence,

$$F(s) = \frac{30}{s} - \frac{48}{s+2} + \frac{18}{s+4}$$

and then

$$f(t) = [30 - 48e^{-2t} + 18e^{-4t}]u(t)$$

Given this expression, we find that

$$\lim_{t \rightarrow 0} f(t) = [30 - 48 + 18] = 0$$

and

$$\lim_{t \rightarrow \infty} f(t) = [30 - 0 + 0] = 30$$

CHAPTER 14 PROBLEMS

- 14.1 Find $v_o(t)$, $t > 0$ in the circuit in Fig. 14.1 using (a) nodal analysis, (b) source transformation and (c) Norton's Theorem.

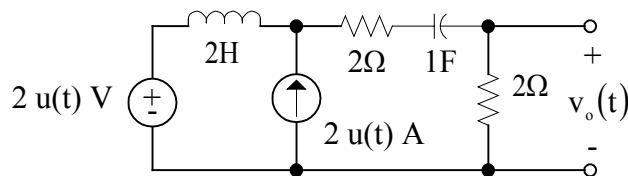

Fig. 14.1

- 14.2 Find $i_o(t)$, $t > 0$ in the circuit in Fig. 14.2 using (a) loop equations and (b) Thevenin's Theorem.

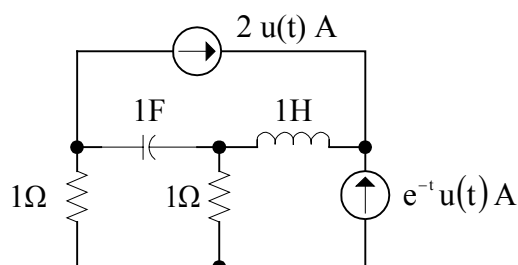

Fig. 14.2

- 14.3 Find $i_o(t)$, $t > 0$ in the circuit in Fig. 14.3.

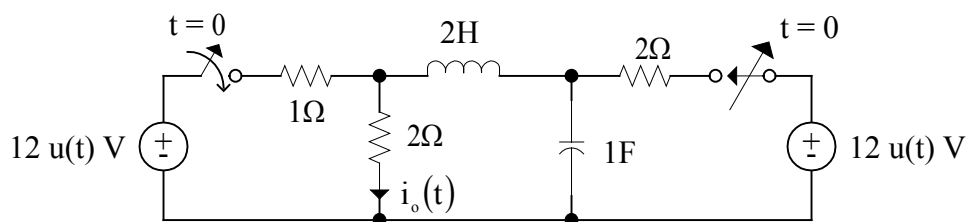

Fig. 14.3

- 14.4 Given the network in Fig. 14.4, determine (a) the voltage transfer function $G(s) = \frac{V_o(s)}{V_s(s)}$, (b) the undamped natural frequency, (c) the damping ratio and (d) the general form of the response of the network to a unit step function.

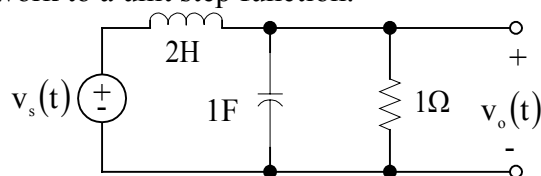

Fig. 14.4

- 14.5 Find the steady-state response $v_o(t)$ for the network in Fig. 14.5.

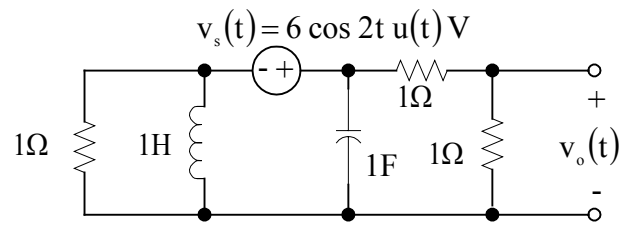

Fig. 14.5

CHAPTER 14 SOLUTIONS

- 14.1 (a) Consider the transformed network in Fig. S14.1(a).

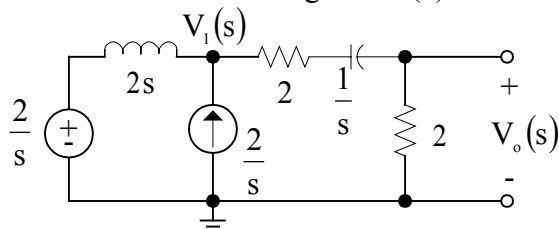

Fig. S14.1(a)

A brute force approach to this problem would be to write two nodal equations for the nodes labeled $V_1(s)$ and $V_0(s)$. Using KCL and summing the currents leaving each node yields the two linearly independent equations

$$\frac{V_1(s) - \frac{2}{s}}{2s} - \frac{2}{s} + \frac{V_1(s) - V_0(s)}{2 + \frac{1}{s}} = 0$$

and

$$\frac{V_0(s) - V_1(s)}{2 + \frac{1}{s}} + \frac{V_0}{2} = 0$$

Solving these equations for $V_0(s)$ and then performing the inverse Laplace transform would yield $v_0(t)$.

Another approach that might be simpler would be to write a node equation for $V_1(s)$, ignoring $V_0(s)$, and then use voltage division to derive $V_0(s)$ once $V_1(s)$ is known. Applying KCL at $V_1(s)$ yields

$$\frac{V_1(s) - \frac{2}{s}}{2s} - \frac{2}{s} + \frac{V_1(s)}{4 + \frac{1}{s}} = 0$$

Rearranging terms we obtain

$$V_1(s) \left[\frac{1}{2s} + \frac{s}{4s + 1} \right] = \frac{1}{s^2} + \frac{2}{s}$$

or

$$V_1(s) \left[\frac{2s^2 + 4s + 1}{2s(4s + 1)} \right] = \frac{2s + 1}{s^2}$$

Solving for $V_1(s)$ yields

$$V_1(s) = \frac{2(2s + 1)(4s + 1)}{s(2s^2 + 4s + 1)}$$

Now applying voltage division

$$\begin{aligned} V_0(s) &= V_1(s) \left(\frac{2}{4 + \frac{1}{s}} \right) \\ &= \frac{4(2s + 1)}{2s^2 + 4s + 1} \end{aligned}$$

This function can be written in partial fraction expansion form as

$$\frac{4s + 2}{s^2 + 2s + \frac{1}{2}} = \frac{A}{s + 0.29} + \frac{B}{s + 1.71}$$

where

$$A = \left. \frac{4s + 2}{s + 1.71} \right|_{s = -0.29} = 0.59$$

and

$$B = \left. \frac{4s + 2}{s + 0.29} \right|_{s = -1.71} = 3.41$$

Therefore,

$$v_0(t) = [0.59e^{-0.29t} + 3.41e^{-1.71t}]u(t) \text{ V}$$

(b) Using source transformation we can convert the voltage source in series with the inductor to a current source in parallel with the inductor yielding the network in Fig. S14.1(b).

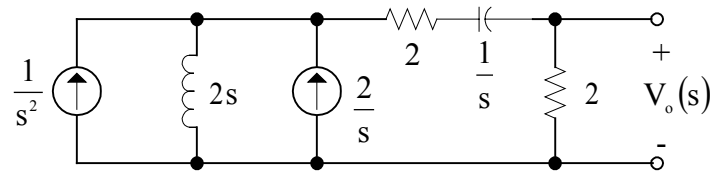

Fig. S14.1(b)

Adding the current sources that are in parallel produces an equivalent source of

$$I_{\text{EQ}}(s) = \frac{1}{s^2} + \frac{2}{s} = \frac{2s+1}{s^2}$$

The network is then reduced to that shown in Fig. S14.1(c).

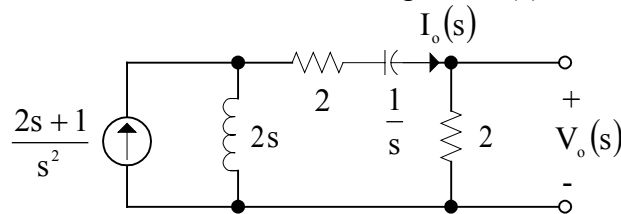

Fig. S14.1(c)

We could, at this point, transform the current source and inductor back to a voltage source in series with the inductor. However, we can simply apply current division at this point with Ohm's Law and derive the answer immediately.

$$\begin{aligned} I_o(s) &= \frac{2s+1}{s^2} \left(\frac{2s}{2s + 2 + \frac{1}{s} + 2} \right) \\ &= \frac{4s+2}{2s^2 + 4s + 1} \end{aligned}$$

And

$$V_o(s) = 2I_o(s) = \frac{4s+2}{s^2 + 2s + \frac{1}{2}}$$

which is identical to the expression obtained earlier.

(c) To apply Norton's Theorem we will break the network to the right of the current source and form a Norton equivalent circuit for the elements to the left of the break as shown in Fig. S14.1(d).

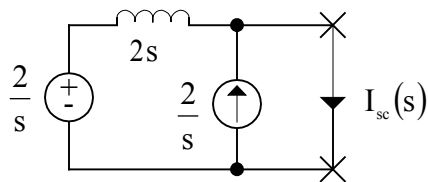

Fig. S14.1(d)

The short-circuit current is

$$\begin{aligned} I_{sc}(s) &= \frac{\frac{2}{s}}{2s} + \frac{2}{s} \\ &= \frac{2s+1}{s^2} \end{aligned}$$

And the Thevenin equivalent impedance is derived from the network in Fig. S14.1(e) as

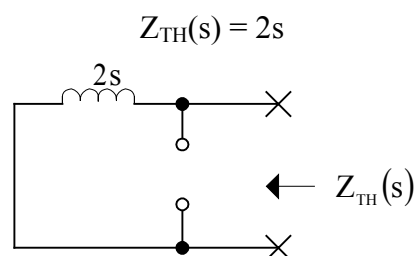

Fig. S14.1(e)

Therefore, attaching the Norton equivalent circuit to the remainder of the network yields the circuit in Fig. S14.1(f) which is the same as that in Fig. S14.1(c).

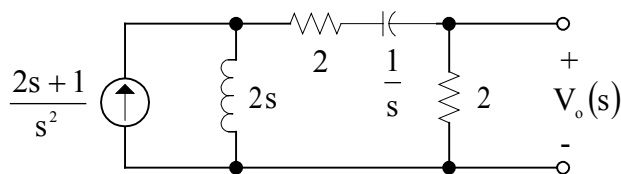

Fig. S14.1(f)

14.2 (a) the transformed network is shown in Fig. S14.2(a).

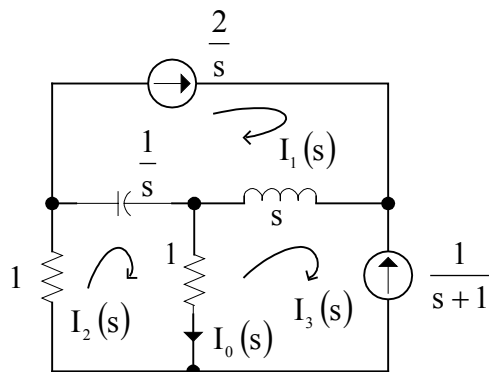

Fig. S14.2(a)

Since there are three “window panes” we will need three linearly independent simultaneous equations to calculate the loop currents. Two of the currents go directly through the current sources and therefore two of the three equations are

$$I_1(s) = \frac{2}{s}$$

$$I_3(s) = \frac{-1}{s+1}$$

The remaining equation is obtained by using KVL around the loop defined by the current $I_2(s)$. That equation is

$$1I_2(s) + \frac{1}{s} [I_2(s) - I_1(s)] + 1 [I_2(s) - I_3(s)] = 0$$

Substituting the first two equations into the last equation yields

$$I_2(s) \left[1 + \frac{1}{s} + 1 \right] = \frac{2}{s^2} - \frac{1}{s+1}$$

or

$$I_2(s) = \frac{-s^2 + 2s + 2}{s(s+1)(2s+1)}$$

Then

$$\begin{aligned}
 I_0(s) &= I_2(s) - I_3(s) \\
 &= \frac{-s^2 + 2s + 2}{s(s+1)(2s+1)} + \frac{1}{s+1} \\
 &= \frac{s^2 + 3s + 2}{s(s+1)(2s+1)} \\
 &= \frac{s+2}{s(2s+1)} \\
 &= \frac{\frac{1}{2}(s+2)}{s\left(s+\frac{1}{2}\right)}
 \end{aligned}$$

Expressing this function in partial fraction expansion form we obtain

$$I_0(s) = \frac{\frac{1}{2}(s+2)}{s\left(s+\frac{1}{2}\right)} = \frac{A}{s} + \frac{B}{s+\frac{1}{2}}$$

where

$$A = \left. \frac{\frac{1}{2}(s+2)}{s+\frac{1}{2}} \right|_{s=0} = 2$$

$$B = \left. \frac{\frac{1}{2}(s+2)}{s} \right|_{s=-\frac{1}{2}} = -\frac{3}{2}$$

Therefore,

$$i_0(t) = \left[2 - \frac{3}{2} e^{-\frac{t}{2}} \right] u(t) \text{ A}$$

(b) In order to apply Thevenin's Theorem, we first break the circuit between the points where the current $I_0(s)$ is located as shown in Fig. S14.2(b).

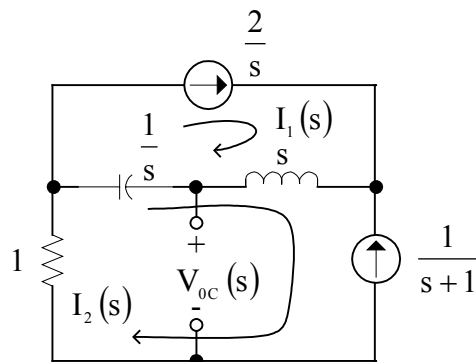

Fig. S14.2(b)

Applying KVL to the closed path in the lower left-hand corner of the network yields

$$1I_2(s) + \frac{1}{s} [I_2(s) - I_1(s)] + V_{oc}(s) = 0$$

where

$$I_1(s) = \frac{2}{s}$$

$$I_2(s) = \frac{-1}{s+1}$$

Combining these equations we obtain

$$V_{oc}(s) = \frac{1}{s+1} + \frac{1}{s(s+1)} + \frac{2}{s^2}$$

$$= \frac{s+2}{s^2}$$

The Thevenin equivalent impedance obtained by looking into the open circuit terminals with all sources made zero (current sources open-circuited) is derived from the network in Fig. S14.2(c).

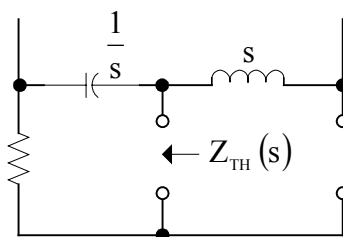

Fig. S14.2(c)

Clearly,

$$Z_{\text{TH}}(s) = \frac{1}{s} + 1 = \frac{s+1}{s}$$

If the resistor containing the $I_0(s)$ is now attached to the Thevenin equivalent circuit we obtain the network in Fig. S14.2(d).

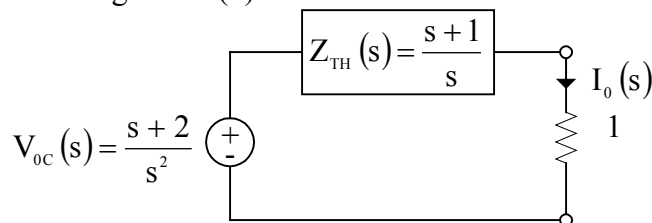

Fig. S14.2(d)

Then

$$\begin{aligned} I_0(s) &= \frac{\frac{s+2}{s^2}}{\frac{s+1}{s} + 1} \\ &= \frac{s+2}{s(2s+1)} \end{aligned}$$

which is identical to the result obtained earlier.

- 14.3 To begin, we first determine the initial conditions in the network prior to switch action. In the steady-state period prior to switch action, the capacitor looks like an open-circuit and the inductor acts like a short-circuit. Therefore, in this time interval the circuit appears as that shown in Fig. S14.3(a).

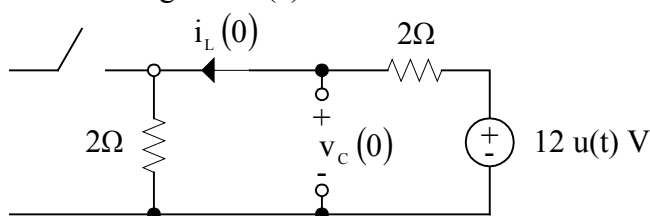

Fig. S14.3(a)

This network indicates that in the steady-state condition for $t < 0$

$$i_L(0) = \frac{12}{2+2} = 3\text{A}$$

and

$$v_c(0) = 12 \left(\frac{2}{2+2} \right) = 6V$$

These conditions cannot change instantaneously and hence the network for $t > 0$ is shown in Fig. S14.3(b).

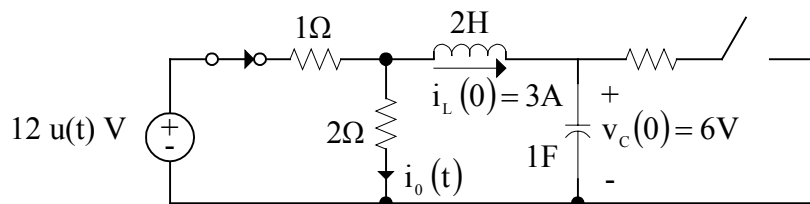

Fig. S14.3(b)

The corresponding transformed network is shown in Fig. S14.3(c).

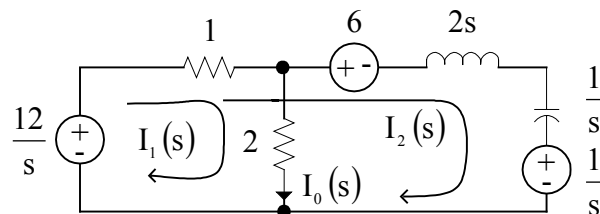

Fig. S14.3(c)

Since the current $I_0(s)$ is located in the center leg of the circuit, we will employ loop equations and specify them such that one of the loops is the same as $I_0(s)$. The two equations for the loop currents specified in the network are

$$\frac{-12}{s} + 1(I_1(s) + I_2(s)) + 2I_1(s) = 0$$

$$\frac{-12}{s} + 1(I_1(s) + I_2(s)) + 6 + 2sI_2(s) + \frac{1}{s}I_2(s) + \frac{1}{s} = 0$$

Solving the second equation for $I_2(s)$ yields

$$I_2(s) = \frac{11 - 6s - sI_1(s)}{2s^2 + s + 1}$$

Substituting this value into the first equation we obtain

$$I_1(s) = I_0(s) = \frac{\frac{1}{6}(30s^2 + s + 12)}{s \left(s^2 + \frac{1}{3}s + \frac{1}{2} \right)}$$

The roots of the quadratic term in the denominator, obtained using the quadratic formula, are

$$s_1, s_2 = -\frac{1}{6} \pm j\frac{\sqrt{17}}{6}$$

The expression for the desired current can now be written in partial fraction expansion form as

$$\frac{\frac{1}{6}(30s^2 + s + 12)}{s\left(s + \frac{1}{6} \pm j\frac{\sqrt{17}}{6}\right)} = \frac{A}{s} + \frac{B}{s - \frac{1}{6} + j\frac{\sqrt{17}}{6}} + \frac{B^*}{s + \frac{1}{6} + j\frac{\sqrt{17}}{6}}$$

where

$$\left. \frac{\frac{1}{6}(30s^2 + s + 12)}{s^2 + \frac{1}{3}s + \frac{1}{2}} \right|_{s=0} = A$$

$$4 = A$$

and

$$\left. \frac{\frac{1}{6}(30s^2 + s + 12)}{s\left(s + \frac{1}{6} + j\frac{\sqrt{17}}{6}\right)} \right|_{s = -\frac{1}{6} + j\frac{\sqrt{17}}{6}} = B$$

The evaluation of this last term involves a lot of tedious, but straight forward, complex algebra. The result is

$$1.09 \angle 62.74^\circ = B$$

Therefore, knowing the values for A and B we can write the final expression for the current in the time domain as

$$i_0(t) = \left[4 + 2(1.09) e^{-\frac{t}{6}} \cos\left(\frac{\sqrt{17}}{6}t + 62.74^\circ\right) \right] u(t) \text{ A}$$

14.4 (a) The transformed network is shown in Fig. S14.4.

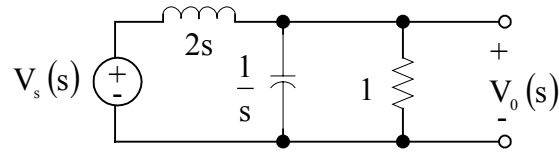

Fig. S14.4

Using voltage division, the voltage transfer function can be expressed as

$$\begin{aligned}
 G(s) = \frac{V_o(s)}{V_s(s)} &= \frac{2\left(\frac{1}{s}\right)}{2 + \frac{1}{s}} \\
 &= \frac{2\left(\frac{1}{s}\right)}{2s + \frac{1}{s}} \\
 &= \frac{2}{4s^2 + 2s + 2} \\
 &= \frac{\frac{1}{2}}{s^2 + \frac{1}{2}s + \frac{1}{2}}
 \end{aligned}$$

(b) The denominator, or characteristic equation, is of the form

$$s^2 + 2\zeta\omega_0 s + \omega_0^2$$

Therefore the undamped natural frequency is

$$\omega_0^2 = \frac{1}{2}$$

and

$$\omega_0 = \frac{1}{\sqrt{2}} = 0.707 \text{ r/s}$$

(c) The damping ratio is derived from the expression

$$2\zeta\omega_0 = \frac{1}{2}$$

and using the value for ω_0 we obtain

$$\zeta = 0.354$$

(d) If the input to the network is a unit step function then

$$V_o(s) = \frac{\frac{1}{2}}{s \left(s^2 + \frac{1}{2}s + \frac{1}{2} \right)}$$

By employing the quadratic formula, we can write this expression in the form

$$V_o(s) = \frac{\frac{1}{2}}{s \left(s + \frac{1}{4} \pm j \frac{\sqrt{7}}{4} \right)}$$

and therefore the general form of the response is

$$v_o(t) = \left[A + B e^{-\frac{1}{4}t} \cos \left(\frac{\sqrt{7}}{4}t + \theta \right) \right] u(t) \text{ v}$$

14.5 The transformed circuit is shown in Fig. S14.5.

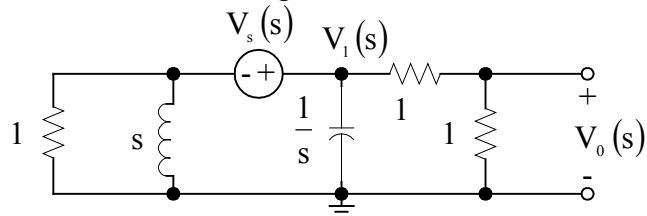

Fig. S14.5

Although the network contains three non-reference nodes, we will try to simplify the analysis by first using a supernode to find $V_1(s)$ and then employing voltage division to determine $V_o(s)$.

KCL for the supernode containing the voltage source is

$$\frac{V_1(s) - V_s(s)}{1} + \frac{V_1(s) - V_s(s)}{s} + \frac{V_1(s)}{\frac{1}{s}} + \frac{V_1(s)}{2} = 0$$

Solving this equation for $V_1(s)$ yields

$$V_1(s) = \left(\frac{s+1}{s^2 + \frac{3}{2}s + 1} \right) V_s(s)$$

And then using voltage division

$$V_o(s) = V_1(s) \left(\frac{1}{1+1} \right)$$

so that

$$V_o(s) = \left[\frac{\frac{1}{2}(s+1)}{s^2 + \frac{3}{2}s + 1} \right] V_s(s)$$

Therefore,

$$H(s) = \frac{\frac{1}{2}(s+1)}{s^2 + \frac{3}{2}s + 1}$$

Since $v_s(t) = 6 \cos 2t u(t)$ V, then $V_M = 6$ and $\omega_0 = 2$. Hence,

$$\begin{aligned} H(j2) &= \frac{\frac{1}{2}(j2+1)}{(j2)^2 + \frac{3}{2}(j2) + 1} \\ &= \frac{-\frac{1}{2}(2.236 \angle 63.43^\circ)}{4.24 \angle -45^\circ} \\ &= 0.264 \angle -71.57^\circ \end{aligned}$$

and

$$\begin{aligned} |H(j2)| &= 0.264 \\ \phi(j2) &= -71.57^\circ \end{aligned}$$

Therefore,

$$\begin{aligned} v_{0ss}(t) &= V_M |H(j2)| \cos(2t + \phi(j2)) \\ &= 1.58 \cos(2t - 71.57^\circ) \text{ V} \end{aligned}$$

CHAPTER 15 PROBLEMS

- 15.1 Find the exponential Fourier series for the waveform in Fig. 15.1.

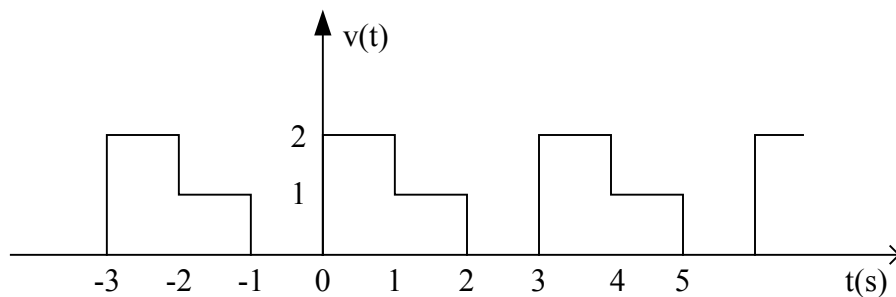

Fig. 15.1

- 15.2 Determine the trigonometric Fourier series for the function shown in Fig. 15.2.

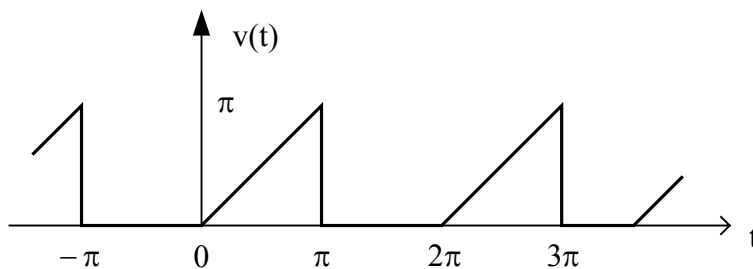

Fig. 15.2

- 15.3 Find the trigonometric Fourier series for the waveform shown in Fig. 15.3.

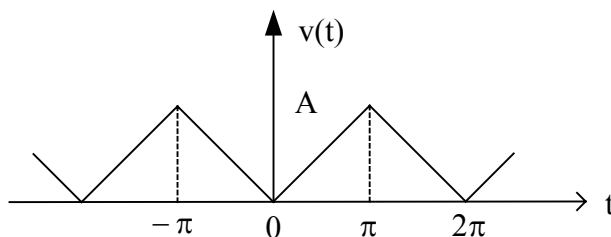

Fig. 15.3

- 15.4 Find the steady-state voltage $v_o(t)$ in the circuit in Fig. 15.4 if the input voltage is the waveform shown in Fig. 15.3 with $A = 1\text{V}$.

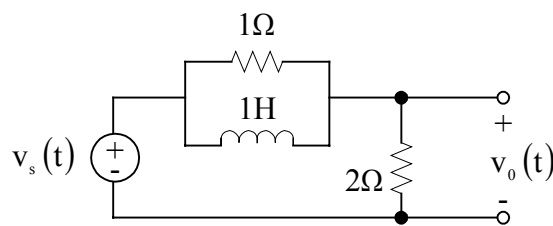

Fig. 15.4

- 15.5 Given the network in Fig. 15.4 with the input source $v_s(t) = 10e^{-2t} u(t)$ V, use the transform technique to find $v_o(t)$.

CHAPTER 15 SOLUTIONS

- 15.1 An examination of the waveform indicates that the period $T = 3$ and $\omega_0 = \frac{2\pi}{T} = \frac{2\pi}{3}$.

The Fourier coefficients are determined from the expression

$$c_n = \frac{1}{T} \int_0^T v(t) e^{-jn\omega_0 t} dt$$

or in this case

$$\begin{aligned} c_n &= \frac{1}{3} \left[\int_0^1 2 e^{-jn\omega_0 t} dt + \int_1^2 1 e^{-jn\omega_0 t} dt \right] \\ &= \frac{-1}{3jn\omega_0} \left[2 e^{-jn\omega_0 t} \Big|_0^1 + e^{-jn\omega_0 t} \Big|_1^2 \right] \\ &= \frac{-1}{3jn\omega_0} \left[2(e^{-jn\omega_0} - 1) + e^{-j2n\omega_0} - e^{-jn\omega_0} \right] \\ &= \frac{-1}{3jn\omega_0} \left[e^{-jn\omega_0} + e^{-j2n\omega_0} - 2 \right] \\ &= \frac{-1}{j2\pi n} \left[e^{-\frac{j2\pi n}{3}} + e^{-\frac{j4\pi n}{3}} - 2 \right] \\ &= \frac{1}{j2\pi n} \left(2 - \left(e^{-\frac{j2\pi n}{3}} + e^{-\frac{j4\pi n}{3}} \right) \right) \\ &= \frac{1}{j2\pi n} \left[2 - 2 e^{-jn\pi} \left(\frac{e^{\frac{jn\pi}{3}} + e^{-\frac{jn\pi}{3}}}{2} \right) \right] \\ &= \frac{1}{jn\pi} \left(1 - e^{-jn\pi} \cos\left(\frac{n\pi}{3}\right) \right) \end{aligned}$$

In addition

$$\begin{aligned} c_0 &= \frac{1}{T} \int_0^3 v(t) dt \\ &= \frac{1}{3} \left[\int_0^1 2 dt + \int_1^2 1 dt \right] \\ &= 1 \end{aligned}$$

Therefore,

$$v(t) = 1 + \sum_{\substack{n=-\infty \\ n \neq 0}}^{\infty} \frac{1}{jn\pi} \left(1 - e^{-jn\pi} \cos\left(\frac{n\pi}{3}\right) \right) e^{jn\omega_0 t}$$

15.2 Since the waveform does not exhibit any symmetry, we will have to determine the coefficients a_0 , a_n and b_n . The a_0 coefficient is

$$a_0 = \frac{1}{2\pi} \int_{-\pi}^{\pi} v(t) dt$$

where, of course, $v(t) = t$ in the interval $0 \leq t \leq \pi$ and zero elsewhere and $\omega_0 = \frac{2\pi}{T} = 1$.

$$\begin{aligned} a_0 &= \frac{1}{2\pi} \int_0^{\pi} t dt \\ &= \frac{1}{2\pi} \left(\frac{t^2}{2} \Big|_0^{\pi} = \frac{\pi}{4} \right) \end{aligned}$$

Recall that a_0 is simply the average value of the waveform and therefore can be calculated by dividing the area under the curve (Area = $\frac{1}{2}bh = \frac{1}{2}(\pi)(\pi) = \frac{\pi^2}{2}$) by the interval (2π) which yields $\frac{\pi}{4}$.

The a_n coefficient is

$$a_n = \frac{2}{2\pi} \int_0^{\pi} t \cos nt dt$$

Using a table of integrals, we find that

$$a_n = \frac{1}{\pi} \left[\frac{1}{n^2} \cos nt + \frac{1}{n} t \sin nt \right]_0^{\pi}$$

The second term is zero at $t = \pi$ and 0 and the first term can be written as

$$a_n = \frac{1}{\pi n^2} [(-1)^n - 1]$$

since the cosine term will be +1 or -1 depending upon the value of n . Thus

$$a_n = \frac{(-1)^n - 1}{\pi n^2}$$

In addition,

$$b_n = \frac{2}{2\pi} \int_0^\pi t \sin t \, dt$$

Once again, using a set of integral tables we find that

$$b_n = \frac{1}{\pi} \left[\frac{1}{n^2} \sin nt - \frac{1}{n} t \cos nt \right]_0^\pi$$

The first term will be zero at each limit, but the second term is nonzero at the upper limit and thus

$$\begin{aligned} b_n &= \frac{-\pi}{n\pi} (-1)^n \\ &= \frac{-(-1)^n}{n} \end{aligned}$$

Therefore, the Fourier series expansion is

$$v(t) = \frac{\pi}{4} + \sum_{n=1}^{\infty} \left[\frac{(-1)^n - 1}{\pi n^2} \right] \cos nt - \frac{(-1)^n}{n} \sin nt$$

- 15.3 To begin our analysis we first note that the waveform is an even function and therefore $b_n = 0$ for all n . Thus, we need to find only the a_0 and a_n coefficients.

For this waveform, we note that $T = 2\pi$ and $\omega_0 = \frac{2\pi}{T} = 1$. a_0 is now

$$a_0 = \frac{1}{2\pi} \int_{-\pi}^{\pi} v(t) \, dt$$

However, recall that a_0 is simply the average value and we can easily compute this number without resorting to solving the above integral. This average value can be obtained by dividing the area by the base, i.e.

$$\text{Area} = 2 \left(\frac{1}{2} bh \right) = 2 \left(\frac{1}{2} (\pi A) \right) = \pi A$$

The base is 2π and therefore

$$a_0 = \frac{\pi A}{2\pi} = \frac{A}{2}$$

Because the function is even,

$$a_n = \frac{4}{2\pi} \int_0^{\pi} \frac{A}{\pi} t \cos nt \, dt$$

where the equation of the straight line function in the interval $0 \leq t \leq \pi$ is $\frac{A}{\pi} t$. So,

$$a_n = \frac{2A}{\pi^2} \int_0^{\pi} t \cos nt \, dt$$

Using a table of integrals, we find that

$$\begin{aligned} a_n &= \frac{2A}{\pi^2} \left[\frac{1}{n^2} \cos nt + \frac{1}{n} t \sin nt \right]_0^{\pi} \\ &= \frac{2A}{\pi^2} \left[\frac{1}{n^2} (\cos n\pi - 1) \right] \\ &= \frac{2A}{(\pi n)^2} (\cos n\pi - 1) \\ &= \frac{-4A}{(\pi n)^2} \quad \text{for } n \text{ odd} \\ &= 0 \quad \text{for } n \text{ even} \end{aligned}$$

Therefore,

$$v(t) = \frac{A}{2} + \sum_{\substack{n=1 \\ n \text{ odd}}}^{\infty} \frac{-4A}{(\pi n)^2} \cos nt$$

15.4 The input voltage for the circuit in Fig. 14.4 is given by the expression

$$v_s(t) = \frac{1}{2} + \sum_{\substack{n=1 \\ n \text{ odd}}}^{\infty} \frac{-4}{(\pi n)^2} \cos nt$$

where $\omega_0 = 1$. The output voltage for the network can be derived using voltage division as

$$\begin{aligned} V_o(j\omega) &= \frac{2}{2 + \frac{(1)(j\omega)}{1+j\omega}} V_s(j\omega) \\ &= \left[\frac{2(1+j\omega)}{2+3j\omega} \right] V_s(j\omega) \end{aligned}$$

and since $\omega_0 = 1$

$$V_o(n) = \left[\frac{2(1+jn)}{2+3jn} \right] V_s(n)$$

Since $V_s(\text{dc}) = \frac{1}{2}$

$$\begin{aligned} V_o(\text{dc}) &= \left(\frac{2}{2} \right) \left(\frac{1}{2} \right) \\ &= \frac{1}{2} \end{aligned}$$

Furthermore,

$$\begin{aligned} V_o(\omega_0) &= \frac{-4}{\pi^2} \left[\frac{2(1+j)}{2+3j} \right] = 0.318 \angle 168.69^\circ \\ V_o(3\omega_0) &= \frac{-4}{9\pi^2} \left[\frac{2(1+j3)}{2+j9} \right] = 3.09 \times 10^{-2} \angle 174.09^\circ \\ V_o(5\omega_0) &= \frac{-4}{25\pi^2} \left[\frac{2(1+j5)}{2+j15} \right] = 1.09 \times 10^{-2} \angle 176.28^\circ \\ V_o(7\omega_0) &= \frac{-4}{49\pi^2} \left[\frac{2(1+j7)}{2+j21} \right] = 5.54 \times 10^{-3} \angle 177.31^\circ \end{aligned}$$

Hence,

$$\begin{aligned} v_o(t) &= \frac{1}{2} + 0.318 \cos(t + 168.69^\circ) + 3.09 \times 10^{-2} \cos(3t + 174.09^\circ) \\ &\quad + 1.09 \times 10^{-2} \cos(5t + 176.28^\circ) + 5.54 \times 10^{-3} \cos(7t + 177.31^\circ) + \dots \end{aligned}$$

15.5 The input function to the network can be expressed in the form

$$V_s(j\omega) = \frac{10}{j\omega + 2}$$

The transfer function for the network obtained in the previous problem is

$$G(j\omega) = \frac{2(1 + j\omega)}{2 + 3j\omega}$$

Then using the time convolution property of the Fourier transform we can express the output of the circuit in the form

$$\begin{aligned} V_o(j\omega) &= G(j\omega) V_s(j\omega) \\ &= \left[\frac{2(1 + j\omega)}{2 + 3j\omega} \right] \left[\frac{10}{2 + j\omega} \right] \\ &= \frac{\frac{20}{3}(j\omega + 1)}{(j\omega + 2) \left(j\omega + \frac{2}{3} \right)} \end{aligned}$$

which can be written as a partial fraction expansion of the form

$$\frac{\frac{20}{3}(j\omega + 1)}{(j\omega + 2) \left(j\omega + \frac{2}{3} \right)} = \frac{A}{j\omega + 2} + \frac{B}{j\omega + \frac{2}{3}}$$

Evaluating the constants yields

$$\left. \frac{\frac{20}{3}(j\omega + 1)}{\left(j\omega + \frac{2}{3} \right)} \right|_{j\omega = -2} = A = 5$$

$$\left. \frac{\frac{20}{3}(j\omega + 1)}{(j\omega + 2)} \right|_{j\omega = -\frac{2}{3}} = B = \frac{5}{3}$$

Therefore,

$$V_o(j\omega) = \frac{5}{j\omega + 2} + \frac{\frac{5}{3}}{j\omega + \frac{2}{3}}$$

And

$$v_o(t) = \left[5 e^{-2t} + \frac{5}{3} e^{\frac{2}{3}t} \right] u(t) \text{ V}$$

CHAPTER 16 PROBLEMS

- 16.1 Find the Y parameters for the network shown in Fig. 16.1 and then find the output voltage of the two-port when a 4mA current source is connected to the input port and a 4k Ω load is connected to the output port.

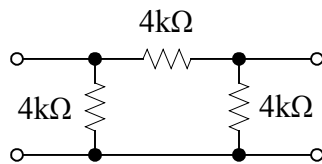

Fig. 16.1

- 16.2 Find the Z parameters for the circuit shown in Fig. 16.2, and then find the current in a $-j4\Omega$ capacitor connected to the output port when a $6 \angle 0^\circ$ V source is connected to the input port.

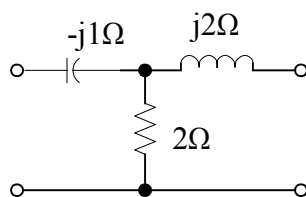

Fig. 16.2

- 16.3 Find the hybrid parameters for the circuit shown in Fig. 16.3. What conclusion can be drawn from this result.

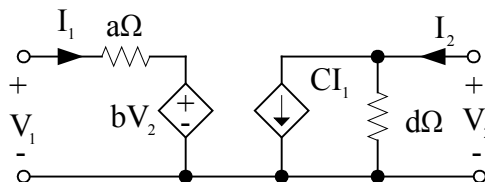

Fig. 16.3

- 16.4 Find the transmission parameters of the network in Fig. 16.1 by treating the circuit as a cascade interconnection of elements.
- 16.5 Check the validity of the answers obtained in problems 16.1 and 16.4 by using the parameter conversion formulas to convert the Y parameters in problem 16.1 to the transmission parameters in problem 16.4.

CHAPTER 16 SOLUTIONS

16.1 The equations for a two-port in terms of the Y parameters are

$$\begin{aligned} I_1 &= y_{11} V_1 + y_{12} V_2 \\ I_2 &= y_{21} V_1 + y_{22} V_2 \end{aligned}$$

Since $y_{11} = \frac{I_1}{V_1}$ with $V_2 = 0$, the network in Fig. S16.1(a) is used to find y_{11} .

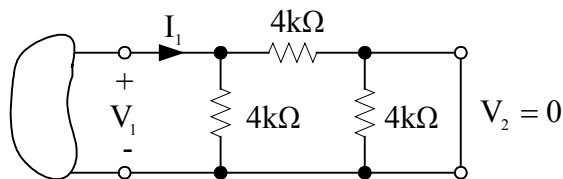

Fig. S16.1(a)

Since V_2 is made zero with the short-circuit, the $4k\Omega$ resistor on the right is shorted and

$$V_1 = I_1 (4k \parallel 4k)$$

or

$$\left. \frac{I_1}{V_1} \right|_{V_2 = 0} = y_{11} = \frac{1}{2k} \text{ S}$$

The parameter y_{12} is found from the expression

$$y_{12} = \left. \frac{I_1}{V_2} \right|_{V_1 = 0}$$

The circuit in Fig. S16.1(b) is used to determine this parameter

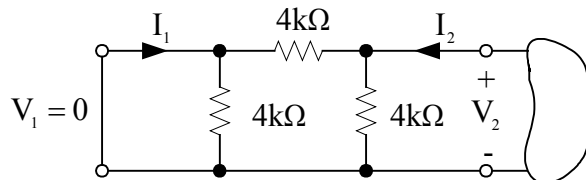

Fig. S16.1(b)

Note in this case, the $4k\Omega$ resistor on the left is shorted and

$$-I_1 (4k) = V_2$$

or

$$\left. \frac{I_1}{V_2} \right|_{V_1=0} = y_{12} = \frac{-1}{4k} \text{S}$$

We could continue this procedure and determine y_{21} and y_{22} in the exact same manner, however, since the network looks the same from either port, we know that $y_{21} = \frac{-1}{4k} \text{S}$ and $y_{22} = \frac{1}{2k} \text{S}$. Therefore, the two-port equations for this network in terms of the Y parameters are

$$\begin{aligned} I_1 &= \frac{1}{2k} V_1 - \frac{1}{4k} V_2 \\ I_2 &= \frac{-1}{4k} V_1 + \frac{1}{2k} V_2 \end{aligned}$$

If we now connect a 4mA current to the input and 4kΩ load to the output, the terminal conditions are

$$\begin{aligned} I_1 &= \frac{4}{k} \text{A} \\ V_2 &= -4k I_2 \end{aligned}$$

The two-port equations now become

$$\begin{aligned} \frac{4}{k} &= \frac{1}{2k} V_1 - \frac{1}{4k} V_2 \\ \frac{-V_2}{4k} &= -\frac{1}{4k} V_1 + \frac{1}{2k} V_2 \end{aligned}$$

or

$$\begin{aligned} \frac{4}{k} &= \frac{1}{2k} V_1 - \frac{1}{4k} V_2 \\ 0 &= -\frac{1}{4k} V_1 + \frac{3}{4k} V_2 \end{aligned}$$

Simplifying

$$\begin{aligned} 16 &= 8V_1 - V_2 \\ 0 &= -V_1 + 3V_2 \end{aligned}$$

or

$$16 = 8(3V_2) - V_2$$

$$V_2 = \frac{16}{23} \text{ V}$$

The network with the terminal conditions attached is shown in Fig. S16.1(c).

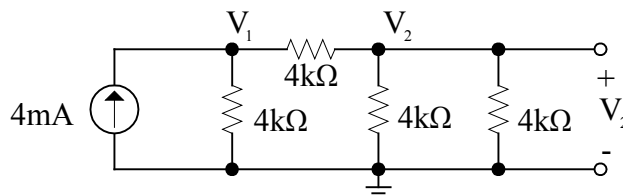

Fig. S16.1(c)

The nodal equations for this network are

$$V_1 \left(\frac{1}{4k} + \frac{1}{4k} \right) - V_2 \left(\frac{1}{4k} \right) = \frac{4}{k}$$

$$-V_1 \left(\frac{1}{4k} \right) + V_2 \left(\frac{1}{4k} + \frac{1}{4k} + \frac{1}{4k} \right) = 0$$

Note that these equations are identical to those obtained earlier.

16.2 The equations for a two-port in terms of the Z parameters are

$$V_1 = z_{11} I_1 + z_{12} I_2$$

$$V_2 = z_{21} I_1 + z_{22} I_2$$

Since $z_{11} = \frac{V_1}{I_1}$ with $I_2 = 0$, the network in Fig. S16.2(a) is used to derive z_{11} .

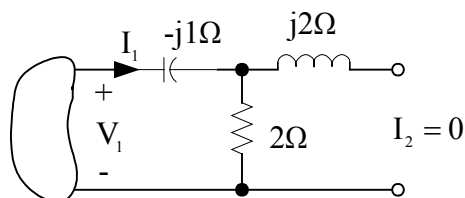

Fig. S16.2(a)

Note that with the output terminals open-circuited, $I_2 = 0$. Then

$$z_{11} = \left. \frac{V_1}{I_1} \right|_{I_2=0} = 2 - j1\Omega$$

Likewise, the parameter z_{12} is found from the expression

$$z_{12} = \left. \frac{V_1}{I_2} \right|_{I_1 = 0}$$

The circuit used to derive this parameter is shown in Fig. S16.2(b).

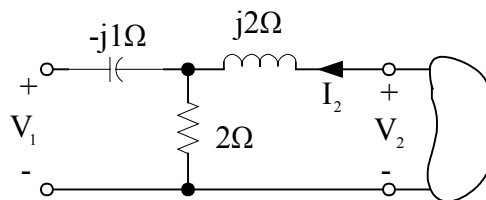

Fig. S16.2(b)

With the input terminals open-circuited, $I_1 = 0$. Since $I_1 = 0$, there is no current in the capacitor and therefore no voltage across it. Then V_1 is the voltage across the 2Ω resistor and

$$V_1 = 2I_2$$

and hence

$$z_{12} = \left. \frac{V_1}{I_2} \right|_{I_1 = 0} = 2\Omega$$

In a similar manner, we find that

$$\begin{aligned} z_{21} &= 2\Omega \\ z_{22} &= 2 + j2\Omega \end{aligned}$$

Therefore, the two-port equations in terms of the Z parameters are

$$\begin{aligned} V_1 &= (2 - j1)I_1 + 2I_2 \\ V_2 &= 2I_1 + (2 + j2)I_2 \end{aligned}$$

If we now apply the terminal conditions, the network is shown in Fig. S16.2(c).

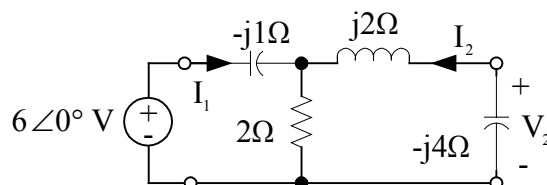

Fig. S16.2(c)

The terminal conditions are

$$\begin{aligned} V_1 &= 6 \angle 0^\circ \text{ V} \\ V_2 &= -(-j4)I_2 \end{aligned}$$

And the two-port equations are

$$\begin{aligned} 6 \angle 0^\circ &= (2 - j1)I_1 + 2I_2 \\ 0 &= 2I_1 + (2 - j2)I_2 \end{aligned}$$

Solving the second equation for I_1 and substituting this value into the first equation yields

$$6 = (-1 + j)(2 - j) + 2I_2$$

or

$$\begin{aligned} I_2 &= \frac{7 - 3j}{2} \\ &= 3.81 \angle -23.2^\circ \text{ A} \end{aligned}$$

16.3 The network is redrawn as shown in Fig. S16.3.

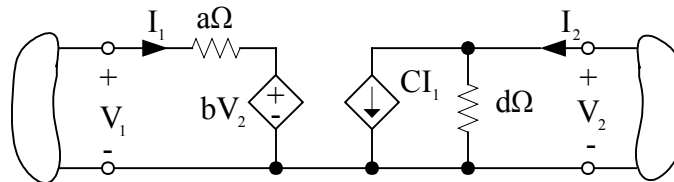

Fig. S16.3

The two-port equations in terms of the hybrid parameters are

$$\begin{aligned} V_1 &= h_{11} I_1 + h_{12} V_2 \\ I_2 &= h_{21} I_1 + h_{22} V_2 \end{aligned}$$

and thus

$$\begin{aligned} h_{11} &= \left. \frac{V_1}{I_1} \right|_{V_2=0} & h_{12} &= \left. \frac{V_1}{V_2} \right|_{I_1=0} \\ h_{21} &= \left. \frac{I_2}{I_1} \right|_{V_2=0} & h_{22} &= \left. \frac{I_2}{V_2} \right|_{I_1=0} \end{aligned}$$

Let us now apply these definitions to the network. Note that

$$h_{11} = \left. \frac{V_1}{I_1} \right|_{V_2 = 0} = a\Omega$$

and

$$h_{12} = \left. \frac{V_1}{V_2} \right|_{I_1 = 0} = b$$

In a similar manner

$$h_{21} = \left. \frac{I_2}{I_1} \right|_{V_2 = 0} = c$$

and

$$h_{22} = \left. \frac{I_2}{V_2} \right|_{I_1 = 0} = \frac{1}{d} \text{S}$$

Note carefully the match between the network in Fig. S16.3 and the hybrid parameters. This network is actually the hybrid model for the basic transistor and given the hybrid parameters for a transistor, the model can be constructed immediately.

- 16.4 The network in Fig. 16.1 can be redrawn in the following manner as shown in Fig. S16.4(a).

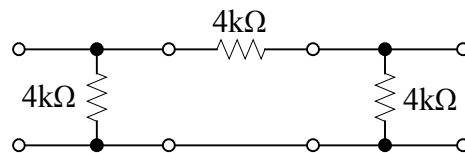

Fig. S16.4(a)

In this form we see that the original network can be drawn as a cascade connection of three networks. The general form of the transmission parameters is

$$\begin{aligned} V_1 &= A V_2 - B I_2 \\ I_1 &= C V_2 - D I_2 \end{aligned}$$

Consider the network in Fig. S16.4(b).

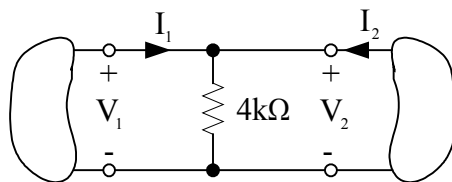

Fig. S16.4(b)

For this network

$$A = \left. \frac{V_1}{V_2} \right|_{I_2 = 0} = 1$$

$$B = \left. \frac{V_1}{-I_2} \right|_{V_2 = 0} = 0$$

$$C = \left. \frac{I_1}{V_2} \right|_{I_2 = 0} = \frac{1}{4k}$$

$$D = \left. \frac{I_1}{-I_2} \right|_{V_2 = 0} = 1$$

Next consider the network in Fig. S16.4(c).

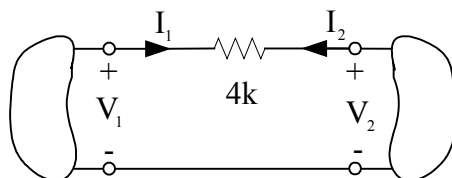

Fig. S16.4(c)

In this case

$$A = \left. \frac{V_1}{V_2} \right|_{I_2 = 0} = 1$$

$$B = \left. \frac{V_1}{-I_2} \right|_{V_2 = 0} = 4k$$

$$C = \left. \frac{I_1}{V_2} \right|_{I_2 = 0} = 0$$

$$D = \left. \frac{I_1}{-I_2} \right|_{V_2 = 0} = 1$$

Since the transmission parameters for the resistor on the right are the same as those for the resistor on the left, we have all the parameters for the individual networks. Now the transmission parameters for the entire network are

$$\begin{aligned}
 \begin{bmatrix} A & B \\ C & D \end{bmatrix} &= \begin{bmatrix} 1 & 0 \\ \frac{1}{4k} & 1 \end{bmatrix} \begin{bmatrix} 1 & 4k \\ 0 & 1 \end{bmatrix} \begin{bmatrix} 1 & 0 \\ \frac{1}{4k} & 1 \end{bmatrix} \\
 &= \begin{bmatrix} 1 & 0 \\ \frac{1}{4k} & 1 \end{bmatrix} \begin{bmatrix} (1)(1) + (4k)\left(\frac{1}{4k}\right) & (1)(0) + (4k)(1) \\ (0)(1) + (1)\left(\frac{1}{4k}\right) & (0)(0) + (1)(1) \end{bmatrix} \\
 &= \begin{bmatrix} 1 & 0 \\ \frac{1}{4k} & 1 \end{bmatrix} \begin{bmatrix} 2 & 4k \\ \frac{1}{4k} & 1 \end{bmatrix} \\
 &= \begin{bmatrix} (1)(2) + (0)\left(\frac{1}{4k}\right) & (1)(4k) + (0)(1) \\ \left(\frac{1}{4k}\right)(2) + (1)\left(\frac{1}{4k}\right) & \left(\frac{1}{4k}\right)(4k) + (1)(1) \end{bmatrix} \\
 &= \begin{bmatrix} 2 & 4k \\ \frac{3}{4k} & 2 \end{bmatrix}
 \end{aligned}$$

- 16.5 The conversion formulas necessary to convert the Y parameters to the transmission parameters are as follows.

$$\begin{bmatrix} A & B \\ C & D \end{bmatrix} = \begin{bmatrix} \frac{-y_{22}}{y_{21}} & \frac{-1}{y_{21}} \\ \frac{-\Delta y}{y_{21}} & \frac{-y_{11}}{y_{21}} \end{bmatrix}$$

where $\Delta y = y_{11} y_{22} - y_{12} y_{21}$. From the results of problem 16.1

$$\begin{bmatrix} y_{11} & y_{12} \\ y_{21} & y_{22} \end{bmatrix} = \begin{bmatrix} \frac{1}{2k} & -\frac{1}{4k} \\ -\frac{1}{4k} & \frac{1}{2k} \end{bmatrix}$$

and $\Delta y = \frac{1}{4k^2} - \frac{1}{16k^2} = \frac{3}{16k^2}$. Hence,

$$A = \frac{-y_{22}}{y_{21}} = \frac{-\frac{1}{2k}}{\frac{-1}{4k}} = 2$$

$$B = \frac{-1}{y_{21}} = \frac{-1}{\frac{-1}{4k}} = 4k$$

$$C = \frac{-\Delta y}{y_{21}} = \frac{\frac{-3}{16k^2}}{\frac{-1}{4k}} = \frac{3}{4k}$$

$$D = \frac{-y_{11}}{y_{21}} = \frac{\frac{-1}{2k}}{\frac{-1}{4k}} = 2$$

These results check with those obtained in problem 16.4.

APPENDIX: Techniques for Solving Linearly Independent Simultaneous Equations

In the solution of various circuit problems we encounter a system of simultaneous equations of the form

$$\begin{aligned}
 a_{11}x_1 + a_{12}x_2 + \cdots + a_{1n}x_n &= b_1 \\
 a_{21}x_1 + a_{22}x_2 + \cdots + a_{2n}x_n &= b_2 \\
 \vdots & \\
 a_{n1}x_1 + a_{n2}x_2 + \cdots + a_{nn}x_n &= b_n
 \end{aligned} \tag{A.1}$$

where the x's and b's are typically voltages and currents or currents and voltages, respectively.

As the title implies, we assume that the equations are linearly independent. As a brief reminder of the meaning of linear independence, consider the following KCL equations written for each node of a three-node network:

$$\frac{3}{2}V_1 - \frac{1}{2}V_2 - 4 = 0 \tag{A.2}$$

$$-\frac{1}{2}V_1 + \frac{5}{6}V_2 + 5 = 0 \tag{A.3}$$

$$-V_1 - \frac{1}{3}V_2 - 1 = 0 \tag{A.4}$$

where V_1 and V_2 are two node voltages that are measured with respect to the third (reference) node. Linear independence implies that we cannot find constants a_1 , a_2 , and a_3 such that

$$a_1\left(\frac{3}{2}V_1 - \frac{1}{2}V_2 - 4\right) + a_2\left(-\frac{1}{2}V_1 + \frac{5}{6}V_2 + 5\right) + a_3\left(-V_1 - \frac{1}{3}V_2 - 1\right) = 0 \tag{A.5}$$

However, in this case if we select $a_1 = a_2 = a_3 = 1$, we obtain

$$\begin{aligned}
 +\frac{3}{2}V_1 - \frac{1}{2}V_2 - 4 - \frac{1}{2}V_1 + \frac{5}{6}V_2 + 5 - V_1 - \frac{1}{3}V_2 - 1 &= 0 \\
 0 &= 0
 \end{aligned}$$

Said another way, this means, for example, that Eqs. (A.2) and (A.3) can be used to obtain Eq. (A.4), and therefore, Eq. (A.4) is linearly dependent on Eqs. (A.2) and (A.3). Furthermore, any two of the equations could be used to obtain the third equation. Therefore, only two of the three equations are linearly independent.

We will now describe three techniques for solving linearly independent simultaneous equations-- Gaussian elimination, determinants and matrices. Our presentation will be very brief and deal only with the elements of these techniques that are needed in this student problem companion.

A.1 Gaussian Elimination

The following example will serve to demonstrate the steps involved in applying this technique.

Example A.1

Let us find the solution to the following set of equations:

$$7X_1 - 4X_2 - X_3 = 4 \quad (\text{A.6})$$

$$-4X_1 + 7X_2 - 2X_3 = 0 \quad (\text{A.7})$$

$$-X_1 - 2X_2 + 3X_3 = -1 \quad (\text{A.8})$$

Solution The algorithm (i.e., step-by-step procedure) for applying the Gaussian elimination method proceeds in the following systematic way. First, we solve Eq. (A.6) for the variable X_1 in terms of the other variables in X_2 and X_3 .

$$X_1 = \frac{4}{7} + \frac{4}{7}X_2 + \frac{1}{7}X_3 \quad (\text{A.9})$$

We then substitute this result into Eqs. (A.7) and (A.8) to obtain

$$\frac{33}{7}X_2 - \frac{18}{7}X_3 = \frac{16}{7} \quad (\text{A.10})$$

$$-\frac{18}{7}X_2 + \frac{20}{7}X_3 = -\frac{3}{7} \quad (\text{A.11})$$

Continuing the reduction we now solve Eq. (A.10) for X_2 in terms of X_3 :

$$X_2 = \frac{16}{33} + \frac{18}{33}X_3 \quad (\text{A.12})$$

Substituting this expression for X_2 into Eq. (A.11) yields

$$\frac{336}{231}X_3 = \frac{189}{231}$$

or

$$X_3 = 0.563 \quad (\text{A.13})$$

Now backtracking through the equations, we can determine X_2 from Eq. (A.12) as

$$X_2 = 0.792$$

and X_1 from Eq. (A.9) as

$$X_1 = 1.104$$

In this simple example we have not addressed such issues as zero coefficients or the impact of round-off errors. We have, however, illustrated the basic procedure.

A.2 Determinants

A *determinant* of order n is a square array of elements a_{ij} arranged as follows:

$$\Delta = \begin{vmatrix} a_{11} & a_{12} & \cdots & a_{1n} \\ a_{21} & a_{22} & \cdots & a_{2n} \\ & \vdots & & \\ a_{n1} & a_{n2} & \cdots & a_{nn} \end{vmatrix} \quad (\text{A.14})$$

The *cofactor* c_{ij} of the element a_{ij} is given by the expression

$$c_{ij} = (-1)^{i+j} A_{ij} \quad (\text{A.15})$$

where A_{ij} is the determinant that remains after the i^{th} row and j^{th} column are deleted.

Example A.2

Given the determinant

$$\Delta = \begin{vmatrix} a_{11} & a_{12} & a_{13} \\ a_{21} & a_{22} & a_{23} \\ a_{31} & a_{32} & a_{33} \end{vmatrix}$$

find the cofactor of the element a_{21} .

Solution The cofactor of c_{21} for the element a_{21} is

$$c_{21} = (-1)^{2+1} \begin{vmatrix} a_{12} & a_{13} \\ a_{32} & a_{33} \end{vmatrix}$$

The numerical value of the determinant is equal to the sum of products of the elements in any row or column and their cofactors.

Example A.3

Let us determine the value of the determinant in Example A.2 using the first row.

Solution

$$\begin{aligned}\Delta &= a_{11}c_{11} + a_{12}c_{12} + a_{13}c_{13} \\ &= a_{11}(-1)^{1+1}A_{11} + a_{12}(-1)^{1+2}A_{12} + a_{13}(-1)^{1+3}A_{13} \\ &= a_{11}\begin{vmatrix} a_{22} & a_{23} \\ a_{32} & a_{33} \end{vmatrix} - a_{12}\begin{vmatrix} a_{21} & a_{23} \\ a_{31} & a_{33} \end{vmatrix} + a_{13}\begin{vmatrix} a_{21} & a_{22} \\ a_{31} & a_{32} \end{vmatrix}\end{aligned}$$

Although the 2-by-2 determinants can be evaluated in the same manner, as illustrated above, the result is simply

$$\begin{vmatrix} a & b \\ c & d \end{vmatrix} = ad - cb \quad (\text{A.16})$$

Therefore, Δ is

$$\Delta = a_{11}(a_{22}a_{33} - a_{32}a_{23}) - a_{12}(a_{21}a_{33} - a_{31}a_{23}) + a_{13}(a_{21}a_{32} - a_{31}a_{22})$$

We could evaluate the determinant using any row or column.

The method of solving the set of simultaneous equations of the form shown in Eq. (A.1) using determinants is known as *Cramer's rule*. Cramer's rule states that if $\Delta \neq 0$ (that is, the equations are linearly independent), the value of the variable x_1 in Eq. (A.1) is given by the expression

$$x_1 = \frac{\Delta_1}{\Delta} = \frac{\begin{vmatrix} b_1 & a_{12} & \dots & a_{1n} \\ b_2 & a_{22} & \dots & a_{2n} \\ \vdots & \vdots & \ddots & \vdots \\ b_n & a_{n2} & \dots & a_{nn} \end{vmatrix}}{\Delta} \quad (\text{A.17})$$

Where Δ_1 is the determinant Δ in which the first column is replaced with the column of coefficients. In the general case, x_i is given by an expression similar to Eq. (A.17) with the i th column replaced by the column of coefficients.

Example A.4

Let us solve the following equations using determinants.

$$\begin{aligned} 2I_1 - 4I_2 &= 8 \\ -4I_1 + 6I_2 &= -4 \end{aligned}$$

Solution In this case, Δ defined by Eq. (A.16) is

$$\Delta = \begin{vmatrix} 2 & -4 \\ -4 & 6 \end{vmatrix} = (2)(6) - (-4)(-4) = -4$$

Then using Eq. (A.17)

$$I_1 = \frac{\begin{vmatrix} 8 & -4 \\ -4 & 6 \end{vmatrix}}{-4} = \frac{(8)(6) - (-4)(-4)}{-4} = -8$$

and

$$I_2 = \frac{\begin{vmatrix} 2 & 8 \\ -4 & -4 \end{vmatrix}}{-4} = \frac{(2)(-4) - (-4)(8)}{-4} = -6$$

A.3 Matrices

A *matrix* is defined to be a rectangular array of numbers arranged in rows and columns and written in the form

$$\begin{bmatrix} a_{11} & a_{12} & \cdots & a_{1n} \\ a_{21} & a_{22} & \cdots & a_{2n} \\ \vdots & \vdots & & \vdots \\ a_{m1} & a_{m2} & \cdots & a_{mn} \end{bmatrix}$$

This array is called an m by n ($m \times n$) matrix because it has m rows and n columns. A matrix is a convenient way of representing arrays of numbers; however, one must remember that the matrix itself has no numerical value. In the preceding array the numbers or functions a_{ij} are called the *elements* of the matrix. Any matrix that has the same number of rows as columns is called a *square matrix*.

Example A.5

Are the following matrices?

$$\begin{bmatrix} a \\ b \\ c \\ d \end{bmatrix}, \begin{bmatrix} 1 & 3 \\ 2 & 4 \end{bmatrix}, \begin{bmatrix} 4 & 3 & 2 & 1 \\ 5 & 6 & 7 & 8 \end{bmatrix}, [1 \ 2 \ 3]$$

Solution Yes.

The identity matrix is a diagonal matrix in which all diagonal elements are equal to one.

Example A.6

Are the following identity matrices?

$$\begin{bmatrix} 1 & 0 \\ 0 & 1 \end{bmatrix}, \begin{bmatrix} 1 & 0 & 0 \\ 0 & 1 & 0 \\ 0 & 0 & 1 \end{bmatrix}, \dots, \begin{bmatrix} 1 & 0 & \dots & \dots & \dots & 0 \\ 0 & 1 & 0 & \dots & \dots & 0 \\ 0 & 0 & 1 & 0 & \dots & 0 \\ \vdots & & & & & \\ 0 & 0 & \dots & \dots & \dots & 1 \end{bmatrix}$$

Solution Yes.

Consider now the multiplication of two matrices. If we are given an $m \times n$ matrix \mathbf{A} and an $n \times r$ matrix \mathbf{B} , the product \mathbf{AB} is defined to be an $m \times r$ matrix \mathbf{C} whose elements are given by the expression

$$c_{ij} = \sum_{k=1}^n a_{ik} b_{kj}, \quad i = 1, \dots, m, \quad j = 1, \dots, r \quad (\text{A.18})$$

Note that the product \mathbf{AB} is defined only when the number of columns of \mathbf{A} is equal to the number of rows of \mathbf{B} .

Multiplication is a “row-by-column” operation. In other words, each element in a row of the first matrix is multiplied by the corresponding element in a column of the second matrix and then the products are summed. This operation is diagrammed as follows:

$$\begin{bmatrix} c_{11} & \dots & c_{1p} \\ \vdots & \boxed{c_{ij}} & \vdots \\ c_{m1} & \dots & c_{mp} \end{bmatrix} = \begin{bmatrix} a_{11} & \dots & a_{1n} \\ a_{i1} & \dots & a_{in} \\ a_{m1} & \dots & a_{mn} \end{bmatrix} \begin{bmatrix} b_{11} & \dots & \boxed{b_{ij}} & \dots & b_{1p} \\ \vdots & & \vdots & & \vdots \\ b_{n1} & \dots & \boxed{b_{nj}} & \dots & b_{np} \end{bmatrix} \quad (\text{A.19})$$

The following examples will illustrate the computational technique.

Example A.7

If

$$\mathbf{A} = \begin{bmatrix} 1 & 3 \\ 2 & 4 \end{bmatrix} \quad \text{and} \quad \mathbf{B} = \begin{bmatrix} 2 & 1 \\ 3 & 5 \end{bmatrix}$$

$$\mathbf{C} = \begin{bmatrix} 1 & 2 \\ 3 & 4 \end{bmatrix} \quad \text{and} \quad \mathbf{D} = \begin{bmatrix} 1 \\ 2 \end{bmatrix}$$

Find \mathbf{AB} and \mathbf{CD} .**Solution**

$$\mathbf{AB} = \begin{bmatrix} (1)(2) + (3)(3) & (1)(1) + (3)(5) \\ (2)(2) + (4)(3) & (2)(1) + (4)(5) \end{bmatrix} = \begin{bmatrix} 11 & 16 \\ 16 & 22 \end{bmatrix}$$

$$\mathbf{CD} = \begin{bmatrix} (1)(1) + (2)(2) \\ (3)(1) + (4)(2) \end{bmatrix} = \begin{bmatrix} 5 \\ 11 \end{bmatrix}$$

The matrix of order $n \times m$ obtained by interchanging the rows and columns of an $m \times n$ matrix \mathbf{A} is called the *transpose* of \mathbf{A} and is denoted by \mathbf{A}^T .

Example A.8

If

$$\mathbf{B} = \begin{bmatrix} 1 & 4 \\ 2 & 5 \\ 3 & 6 \end{bmatrix}$$

Find \mathbf{B}^T .**Solution**

$$\mathbf{B}^T = \begin{bmatrix} 1 & 2 & 3 \\ 4 & 5 & 6 \end{bmatrix}$$

As defined for determinants, the *cofactor* A_{ij} of the element a_{ij} of any square matrix \mathbf{A} is equal to the product $(-1)^{i+j}$ and the determinant of the submatrix obtained from \mathbf{A} by deleting row i and column j .

Example A.9

Given the matrix

$$\mathbf{A} = \begin{bmatrix} \mathbf{a}_{11} & \mathbf{a}_{12} & \mathbf{a}_{13} \\ \mathbf{a}_{21} & \mathbf{a}_{22} & \mathbf{a}_{23} \\ \mathbf{a}_{31} & \mathbf{a}_{32} & \mathbf{a}_{33} \end{bmatrix}$$

Find the cofactors A_{11} , A_{12} , and A_{22} .

Solution The cofactors A_{11} , A_{12} , and A_{22} are

$$\begin{aligned} A_{11} &= (-1)^2 \begin{vmatrix} \mathbf{a}_{22} & \mathbf{a}_{23} \\ \mathbf{a}_{32} & \mathbf{a}_{33} \end{vmatrix} = \mathbf{a}_{22}\mathbf{a}_{33} - \mathbf{a}_{32}\mathbf{a}_{23} \\ A_{12} &= (-1)^3 \begin{vmatrix} \mathbf{a}_{21} & \mathbf{a}_{23} \\ \mathbf{a}_{31} & \mathbf{a}_{33} \end{vmatrix} = -(\mathbf{a}_{21}\mathbf{a}_{33} - \mathbf{a}_{31}\mathbf{a}_{23}) \\ A_{22} &= (-1)^4 \begin{vmatrix} \mathbf{a}_{11} & \mathbf{a}_{13} \\ \mathbf{a}_{31} & \mathbf{a}_{33} \end{vmatrix} = \mathbf{a}_{11}\mathbf{a}_{33} - \mathbf{a}_{31}\mathbf{a}_{13} \end{aligned}$$

The *adjoint* of the matrix \mathbf{A} ($\text{adj } \mathbf{A}$) is the transpose of the matrix obtained from \mathbf{A} by replacing each element a_{ij} by its cofactors A_{ij} . In others words, if

$$\mathbf{A} = \begin{bmatrix} \mathbf{a}_{11} & \mathbf{a}_{12} & \cdots & \mathbf{a}_{1n} \\ \mathbf{a}_{21} & \mathbf{a}_{22} & \cdots & \cdot \\ \vdots & \vdots & & \vdots \\ \mathbf{a}_{n1} & \cdots & \cdots & \mathbf{a}_{nn} \end{bmatrix}$$

then

$$\text{adj } \mathbf{A} = \begin{bmatrix} A_{11} & A_{21} & \cdots & A_{n1} \\ A_{12} & A_{22} & \cdots & \cdot \\ \vdots & \vdots & & \vdots \\ A_{1n} & \cdots & \cdots & A_{nn} \end{bmatrix}$$

If \mathbf{A} is a square matrix and if there exists a square matrix \mathbf{A}^{-1} such that

$$\mathbf{A}^{-1}\mathbf{A} = \mathbf{A}\mathbf{A}^{-1} = \mathbf{I} \tag{A.20}$$

Then \mathbf{A}^{-1} is called the *inverse* of \mathbf{A} . It can be shown that the inverse of the matrix \mathbf{A} is equal to the adjoint divided by the determinant (written here as $|\mathbf{A}|$); that is

$$\mathbf{A}^{-1} = \frac{\text{adj } \mathbf{A}}{|\mathbf{A}|} \quad (\text{A.21})$$

Example A.10

Given

$$\mathbf{B} = \begin{bmatrix} 2 & 3 & 1 \\ 1 & 2 & 3 \\ 3 & 1 & 2 \end{bmatrix}$$

Find \mathbf{B}^{-1} .

Solution

$$\begin{aligned} |\mathbf{B}| &= 2 \begin{vmatrix} 2 & 3 \\ 1 & 2 \end{vmatrix} - 1 \begin{vmatrix} 3 & 1 \\ 1 & 2 \end{vmatrix} + 3 \begin{vmatrix} 3 & 1 \\ 2 & 3 \end{vmatrix} \\ &= 2 - 5 + 21 = 18 \end{aligned}$$

and

$$\text{adj } \mathbf{B} = \begin{bmatrix} 1 & -5 & 7 \\ 7 & 1 & -5 \\ -5 & 7 & 1 \end{bmatrix}$$

Therefore,

$$\mathbf{B}^{-1} = \frac{1}{18} \begin{bmatrix} 1 & -5 & 7 \\ 7 & 1 & -5 \\ -5 & 7 & 1 \end{bmatrix}$$

We now have the tools necessary to solve Eqs. (A.1) using matrices. The following example illustrates the approach.

Example A.11

The node equations for a network are

$$2V_1 + 3V_2 + V_3 = 9$$

$$\begin{aligned}V_1 + 2V_2 + 3V_3 &= 6 \\3V_1 + V_2 + 2V_3 &= 8\end{aligned}$$

Let us solve this set of equations using matrix analysis.

Solution Note that this set of simultaneous equations can be written as a single matrix equation in the form

$$\begin{bmatrix} 2 & 3 & 1 \\ 1 & 2 & 3 \\ 3 & 1 & 2 \end{bmatrix} \begin{bmatrix} V_1 \\ V_2 \\ V_3 \end{bmatrix} = \begin{bmatrix} 9 \\ 6 \\ 8 \end{bmatrix}$$

or

$$\mathbf{AV} = \mathbf{I}$$

Multiplying both sides of the preceding equation through \mathbf{A}^{-1} yields

$$\mathbf{A}^{-1}\mathbf{AV} = \mathbf{A}^{-1}\mathbf{I}$$

or

$$\mathbf{V} = \mathbf{A}^{-1}\mathbf{I}$$

\mathbf{A}^{-1} was calculated in Example A.10. Employing that inverse here, we obtain

$$\mathbf{V} = \frac{1}{18} \begin{bmatrix} 1 & -5 & 7 \\ 7 & 1 & -5 \\ -5 & 7 & 1 \end{bmatrix} \begin{bmatrix} 9 \\ 6 \\ 8 \end{bmatrix}$$

or

$$\begin{bmatrix} V_1 \\ V_2 \\ V_3 \end{bmatrix} = \frac{1}{18} \begin{bmatrix} 35 \\ 29 \\ 5 \end{bmatrix}$$

and hence,

$$V_1 = \frac{35}{18}, V_2 = \frac{29}{18}, \text{ and } V_3 = \frac{5}{18}$$

EQUATIONS

CHAPTER 1

Electric current-charge relationship

$$i(t) = \frac{dq(t)}{dt} \quad \text{or} \quad q(t) = \int_{-\infty}^t i(x) dx$$

Power

$$\frac{dw}{dt} = p = vi$$

Voltage-energy relationship

$$v = \frac{dw}{dq}$$

Energy

$$\Delta w = \int_{t_1}^{t_2} p dt = \int_{t_1}^{t_2} vi dt$$

CHAPTER 2

Ohm's law

$$v(t) = R \times i(t) \quad \text{or} \quad i(t) = Gv(t) \quad \text{where} \quad G = \frac{1}{R}$$

Two series resistors & voltage divider

$$i(t) = \frac{v(t)}{R_1 + R_2}$$

$$v_{R_1} = \frac{R_1}{R_1 + R_2} v(t)$$

$$v_{R_2} = \frac{R_2}{R_1 + R_2} v(t)$$

Power

$$p(t) = v(t)i(t) = Ri^2(t) = \frac{v^2(t)}{R}$$

Kirchhoff's Current Law (KCL)

$$\sum_{j=1}^N i_j(t) = 0$$

Kirchhoff's Voltage Law (KVL)

$$\sum_{j=1}^N v_j(t) = 0$$

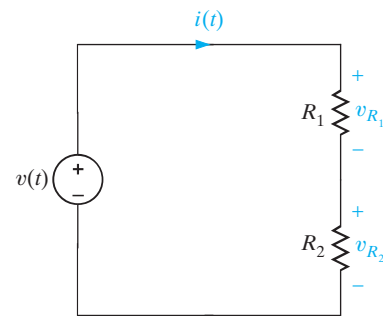

Multiple series resistors & voltage divider

$$R_S = R_1 + R_2 + \dots + R_N$$

$$i(t) = \frac{v(t)}{R_S}$$

$$v_{R_i} = \frac{R_i}{R_S} v(t)$$

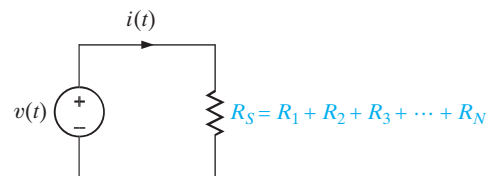
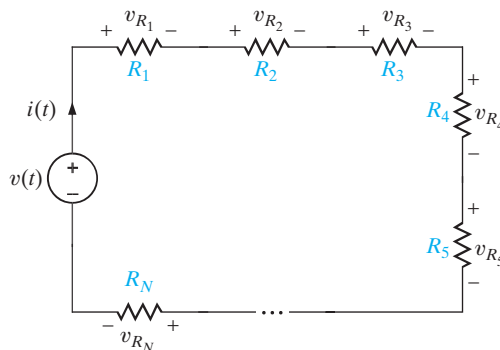

Two parallel resistors & current divider

$$R_p = \frac{R_1 R_2}{R_1 + R_2}$$

$$v(t) = R_p i(t) = \frac{R_1 R_2}{R_1 + R_2} i(t)$$

$$i_1(t) = \frac{R_2}{R_1 + R_2} i(t)$$

$$i_2(t) = \frac{R_1}{R_1 + R_2} i(t)$$

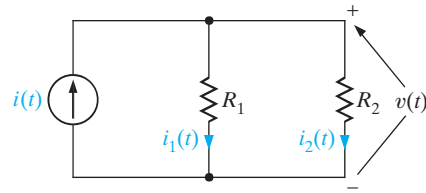

Multiple parallel resistors & current divider

$$\frac{1}{R_p} = \sum_{i=1}^N \frac{1}{R_i}$$

$$i_j(t) = \frac{R_p}{R_j} i_o(t)$$

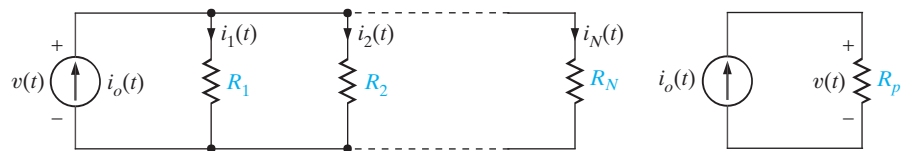

Delta-to-wye resistance conversion

$$R_a = \frac{R_1 R_2}{R_1 + R_2 + R_3}$$

$$R_b = \frac{R_2 R_3}{R_1 + R_2 + R_3}$$

$$R_c = \frac{R_1 R_3}{R_1 + R_2 + R_3}$$

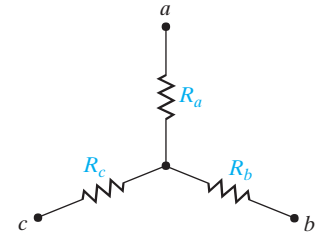
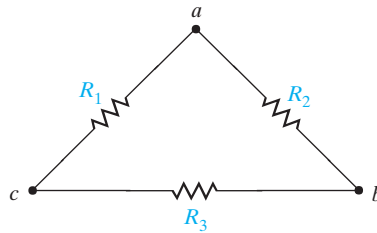

Delta-to-wye resistance conversion (Special case: Identical resistors)

$$R_Y = \frac{1}{3} R_\Delta$$

Wye-to-delta resistance conversion (Special case: Identical resistors)

$$R_\Delta = 3R_Y$$

Wye-to-delta resistance conversion

$$R_1 = \frac{R_a R_b + R_b R_c + R_a R_c}{R_b}$$

$$R_2 = \frac{R_a R_b + R_b R_c + R_a R_c}{R_c}$$

$$R_3 = \frac{R_a R_b + R_b R_c + R_a R_c}{R_a}$$

CHAPTER 3

Ohm's law expressed in node voltages

$$i = \frac{v_m - v_N}{R}$$

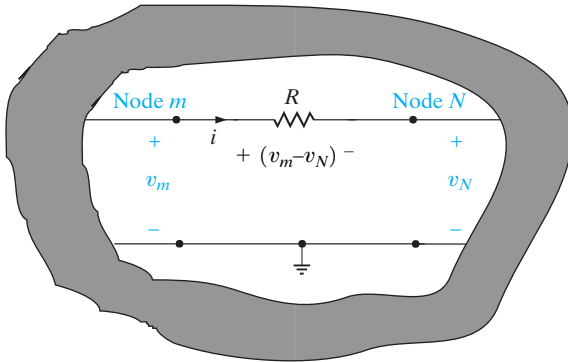

CHAPTER 4

Ideal op amp

$$i_+ = i_- = 0$$

$$v_+ = v_-$$

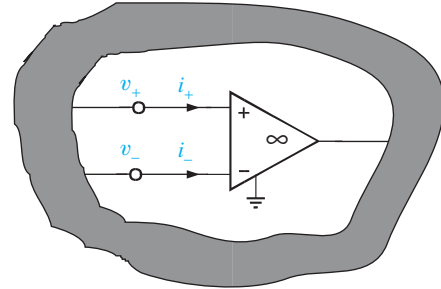

Ohm's law expressed in loop currents

$$v_3 = (i_1 - i_2)R_3$$

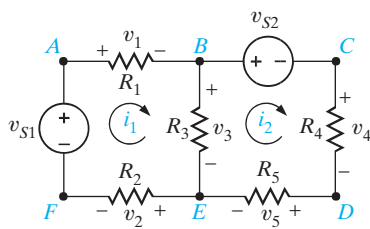

CHAPTER 5

Equivalent circuit forms

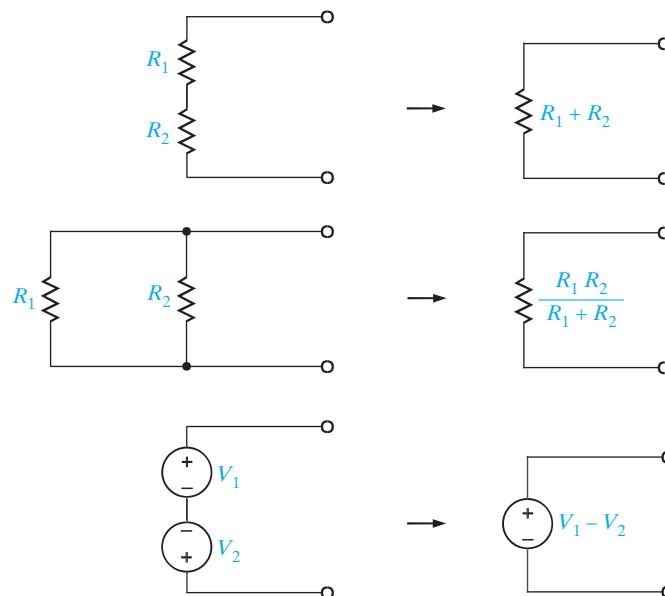

Equivalent circuit forms (continued)

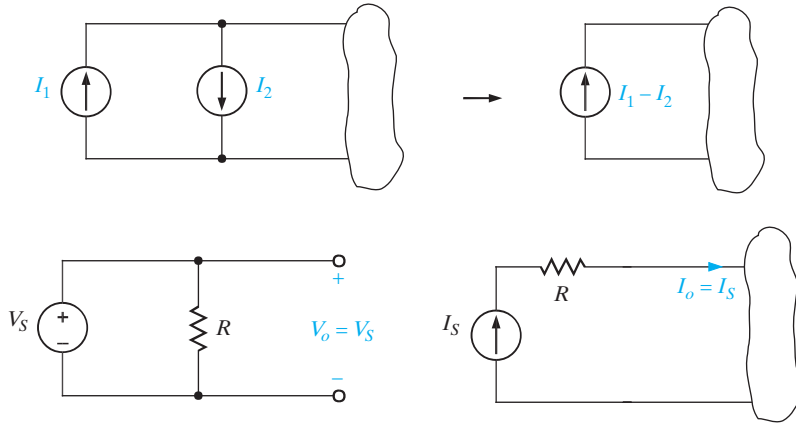

Thévenin & Norton equivalent circuits

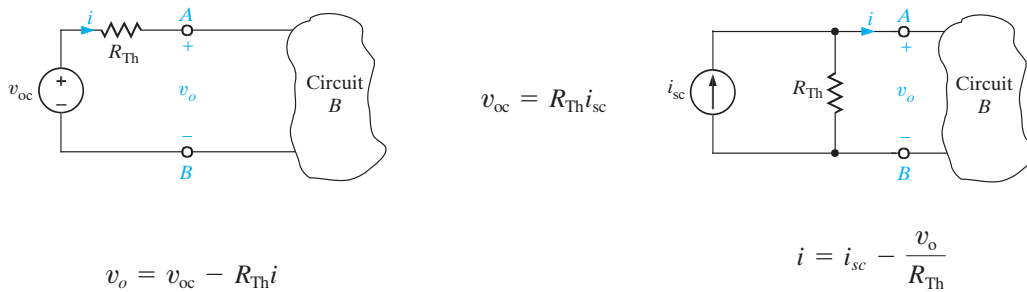

Maximum power transfer theorem
(Thévenin v and R fixed, load R_L variable)

$R_L = R$

$P_{load} = \frac{v^2}{4R}$

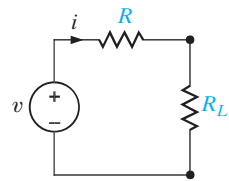

v & R fixed, R_L variable

CHAPTER 6

Parallel-plate capacitor-Capacitance

$C = \frac{\epsilon_o A}{d}$

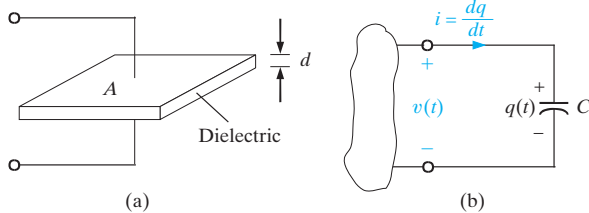

Charge stored on a capacitor

$q = Cv$

Current-voltage relationship of a capacitor

$i = C \frac{dv}{dt}$

$v(t) = \frac{1}{C} \int_{-\infty}^t i(x) dx$

Energy stored in a capacitor

$$w_C(t) = \frac{1}{2} \frac{q^2(t)}{C} = \frac{1}{2} C v^2(t) \text{ J}$$

Current-voltage relationship of an inductor

$$v(t) = L \frac{di(t)}{dt}$$

$$i(t) = \frac{1}{L} \int_{-\infty}^t v(x) dx$$

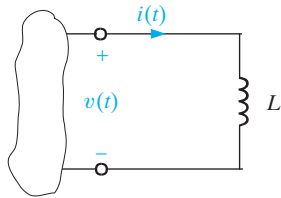
**Energy stored in an inductor**

$$w_L(t) = \frac{1}{2} L i^2(t) \text{ J}$$

Capacitors connected in series

$$\frac{1}{C_S} = \sum_{i=1}^N \frac{1}{C_i}$$

Capacitors connected in parallel

$$C_p = \sum_{i=1}^N C_i$$

Inductors connected in series

$$L_S = \sum_{i=1}^N L_i$$

Inductors connected in parallel

$$\frac{1}{L_p} = \sum_{i=1}^N \frac{1}{L_i}$$

CHAPTER 7**First-order circuits****The unit step function**

$$u(t) = \begin{cases} 0 & t < 0 \\ 1 & t > 0 \end{cases}$$

General form of the step response of a first-order circuit excited at $t = t_0$

$$x(t) = x(\infty) + [x(t_0) - x(\infty)] e^{-(t-t_0)/\tau}, \quad t = t_0$$

where $x(t_0)$ is the initial value and $x(\infty)$ is the final value.

Time constant of a first-order capacitive circuit

$$\tau = R_{Th} C$$

Time constant of a first-order inductive circuit

$$\tau = \frac{L}{R_{Th}}$$

Second-order circuits**Characteristic equation of a second-order circuit**

$$s^2 + 2\zeta\omega_0 s + \omega_0^2 = 0$$

Roots of the characteristic equation

$$s_1 = -\zeta\omega_0 + \omega_0 \sqrt{\zeta^2 - 1}$$

$$s_2 = -\zeta\omega_0 - \omega_0 \sqrt{\zeta^2 - 1}$$

Overdamped response (i.e., $\zeta > 1$)

$$x(t) = K_1 e^{-(\zeta\omega_0 - \omega_0 \sqrt{\zeta^2 - 1})t} + K_2 e^{-(\zeta\omega_0 + \omega_0 \sqrt{\zeta^2 - 1})t}$$

Critically damped response (i.e., $\zeta = 1$)

$$x(t) = B_1 e^{-\zeta\omega_0 t} + B_2 t e^{-\zeta\omega_0 t}$$

Underdamped response (i.e., $\zeta < 1$)

$$x(t) = e^{-\sigma t} (A_1 \cos \omega_d t + A_2 \sin \omega_d t),$$

where $\sigma = \zeta\omega_0$, and $\omega_d = \omega_0 \sqrt{1 - \zeta^2}$

CHAPTER 8

General form of a sinusoidal waveform

$$x(t) = X_M \sin(\omega t + \theta) \text{ where } \omega = \frac{2\pi}{T} = 2\pi f$$

Conversion between sine and cosine functions

$$\cos \omega t = \sin\left(\omega t + \frac{\pi}{2}\right)$$

$$\sin \omega t = \cos\left(\omega t - \frac{\pi}{2}\right)$$

Impedance

$$\mathbf{Z} = \frac{\mathbf{V}}{\mathbf{I}} = \frac{V_M \angle \theta_v}{I_M \angle \theta_i} = \frac{V_M}{I_M} \angle \theta_v - \theta_i = Z \angle \theta_z$$

Impedances connected in series

$$\mathbf{Z}_S = \sum_{i=1}^N \mathbf{Z}_i$$

Impedances connected in parallel

$$\frac{1}{\mathbf{Z}_p} = \sum_{i=1}^N \frac{1}{\mathbf{Z}_i}$$

Impedances of R , L , and C

Passive element	Impedance
R	$\mathbf{Z} = R$
L	$\mathbf{Z} = j\omega L = jX_L = \omega L \angle 90^\circ, X_L = \omega L$
C	$\mathbf{Z} = \frac{1}{j\omega C} = jX_C = -\frac{1}{\omega C} \angle 90^\circ, X_C = -\frac{1}{\omega C}$

Admittance

$$\mathbf{Y} = \frac{1}{\mathbf{Z}} = \frac{\mathbf{I}}{\mathbf{V}}$$

Admittances of R , L , and C

$$\mathbf{Y}_R = \frac{1}{R} = G$$

$$\mathbf{Y}_L = \frac{1}{j\omega L} = -\frac{1}{\omega L} \angle 90^\circ$$

$$\mathbf{Y}_C = j\omega C = \omega C \angle 90^\circ$$

Admittances connected in series

$$\frac{1}{\mathbf{Y}_S} = \sum_{i=1}^N \frac{1}{\mathbf{Y}_i}$$

Admittances connected in parallel

$$\mathbf{Y}_p = \sum_{i=1}^N \mathbf{Y}_i$$

CHAPTER 9

Average (real) power absorbed by an impedance (watts)

$$P = \frac{1}{2} V_M I_M \cos(\theta_v - \theta_i)$$

Maximum average power transfer theorem (When V_{OC} and Z_{Th} fixed, load Z_L variable)

$$\mathbf{Z}_L = R_L + jX_L = R_{Th} - jX_{Th} = \mathbf{Z}_{Th}^*$$

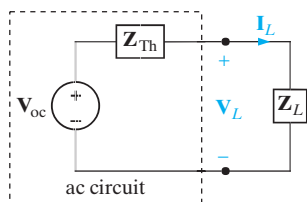

Average power absorbed by a resistor

$$P = I_{\text{rms}}^2 R = \frac{V_{\text{rms}}^2}{R}$$

Power factor (pf)

$$\text{pf} = \cos(\theta_v - \theta_i) = \cos \theta_{Z_L}$$

Complex power (volt-amperes)

$$\begin{aligned} \mathbf{S} &= P + jQ = V_{\text{rms}} \angle \theta_v I_{\text{rms}} \angle -\theta_i \\ &= V_{\text{rms}} I_{\text{rms}} \angle \theta_v - \theta_i = I_{\text{rms}}^2 \mathbf{Z} \end{aligned}$$

V_{oc} & Z_{Th} fixed, Z_L variable

Maximum average power transfer theorem
(Special case: $X_L = 0$)

$$R_L = \sqrt{R_{Th}^2 + X_{Th}^2}$$

RMS value of a sinusoidal waveform

$$I_{rms} = \frac{I_M}{\sqrt{2}}$$

Average power absorbed in terms of rms values

$$P = V_{rms} I_{rms} \cos(\theta_v - \theta_i)$$

Average (real) power (watts)

$$P = \text{Re}(\mathbf{S}) = V_{rms} I_{rms} \cos(\theta_v - \theta_i) = I_{rms}^2 \text{Re}(\mathbf{Z})$$

Reactive power (vars)

$$Q = \text{Im}(\mathbf{S}) = V_{rms} I_{rms} \sin(\theta_v - \theta_i) = I_{rms}^2 \text{Im}(\mathbf{Z})$$

Power triangle relationship

$$\tan(\theta_v - \theta_i) = \tan \theta_Z = \frac{Q}{P}$$

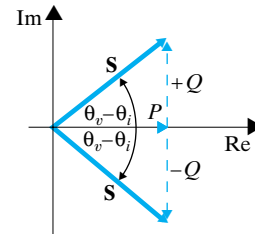

CHAPTER 10

Magnetic flux, voltage and current relationships

$$\lambda = N\phi = Li \text{ webers}$$

$$v = \frac{d\lambda}{dt} = L \frac{di}{dt}$$

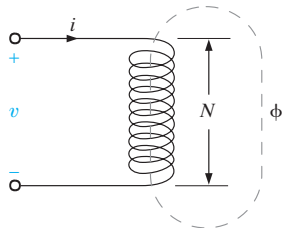

Phasor voltage-current relationships for mutually coupled coils

$$\mathbf{V}_1 = j\omega L_1 \mathbf{I}_1 + j\omega M \mathbf{I}_2$$

$$\mathbf{V}_2 = j\omega L_2 \mathbf{I}_2 + j\omega M \mathbf{I}_1$$

Energy stored in magnetically coupled inductors

$$w(t) = \frac{1}{2} L_1 [i_1(t)]^2 + \frac{1}{2} L_2 [i_2(t)]^2 \pm M i_1(t) i_2(t)$$

The coefficient of coupling

$$k = \frac{M}{\sqrt{L_1 L_2}} \text{ where } 0 \leq k \leq 1$$

Ideal transformer equations in phasor form

$$\frac{\mathbf{V}_1}{\mathbf{V}_2} = \frac{\mathbf{I}_2}{\mathbf{I}_1} = \frac{N_1}{N_2}$$

Voltage-current relationships for mutually coupled coils

$$v_1(t) = L_1 \frac{di_1(t)}{dt} + M \frac{di_2(t)}{dt}$$

$$v_2(t) = M \frac{di_1(t)}{dt} + L_2 \frac{di_2(t)}{dt}$$

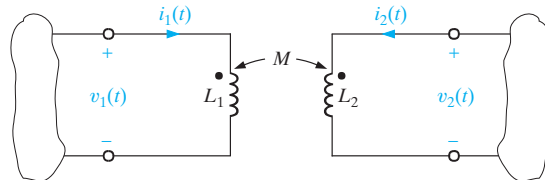

Ideal transformer equations

$$\frac{v_1}{v_2} = -\frac{i_1}{i_2} = \frac{N_1}{N_2}$$

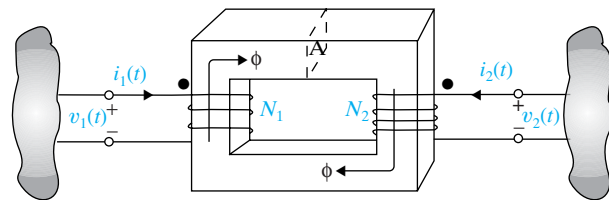

The turns ratio of a transformer

$$n = \frac{N_2}{N_1}$$

CHAPTER 11

Three-phase terminology

Quantity	Wye	Delta
I_a, I_b, I_c	Line current (I_L)	
	Phase current (I_p)	
V_{an}, V_{bn}, V_{cn}	Line-to-neutral voltage (V_p)	
	Phase voltage (V_p)	
	Line-to-line, phase-to-phase, line voltage (V_L)	
V_{ab}, V_{bc}, V_{ca}		Phase voltage (V_p)
I_{ab}, I_{bc}, I_{ca}		Phase current (I_p)

Voltage, current, and impedance relationships of Y and Δ configurations

	Y	Δ
Line voltage (V_{ab} or V_{AB})	$\sqrt{3} V_p / \phi + 30^\circ$ $= V_L / \phi + 30^\circ$	$V_L / \phi + 30^\circ$
Line current I_{aA}	I_L / θ	I_L / θ
Phase voltage	V_p / ϕ (V_{an} or V_{AN})	$\sqrt{3} V_p / \phi + 30^\circ$
Phase current	I_L / θ	$\frac{I_L}{\sqrt{3}} / \theta + 30^\circ$
Load impedance	$Z_Y / \phi - \theta$	$3 Z_Y / \phi - \theta$

CHAPTER 12

Resonant frequency of a series or parallel RLC circuit

$$\omega_0 = \frac{1}{\sqrt{LC}}$$

Quality factor of a series RLC circuit

$$Q = \frac{\omega_0 L}{R} = \frac{1}{\omega_0 CR} = \frac{1}{R} \sqrt{\frac{L}{C}}$$

Bandwidth of a series RLC circuit

$$BW = \omega_{HI} - \omega_{LO} = \frac{\omega_0}{Q}$$

where

$$\omega_{LO} = \omega_0 \left[-\frac{1}{2Q} + \sqrt{\left(\frac{1}{2Q}\right)^2 + 1} \right]$$

$$\omega_{HI} = \omega_0 \left[\frac{1}{2Q} + \sqrt{\left(\frac{1}{2Q}\right)^2 + 1} \right]$$

and

$$\omega_0^2 = \omega_{LO} \omega_{HI}$$

Quality factor of a parallel RLC circuit

$$Q = \frac{\omega_0}{BW} = R \sqrt{\frac{C}{L}}$$

Bandwidth of a parallel RLC circuit

$$BW = \omega_{HI} - \omega_{LO} = \frac{1}{RC}$$

where

$$\omega_{LO} = -\frac{1}{2RC} + \sqrt{\frac{1}{(2RC)^2} + \frac{1}{LC}}$$

and

$$\omega_{HI} = \frac{1}{2RC} + \sqrt{\frac{1}{(2RC)^2} + \frac{1}{LC}}$$

Half-power (break) frequency of a first-order RC filter

$$\omega = \frac{1}{\tau} = \frac{1}{RC}$$

Bandwidth of a series RLC bandpass filter

$$BW = \omega_{HI} - \omega_{LO} = \frac{R}{L}$$

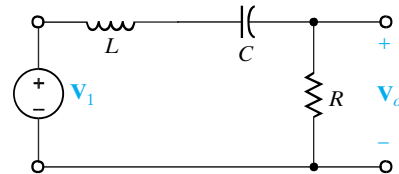

CHAPTER 13

Laplace transform of a function $f(t)$

$$\mathcal{L}[f(t)] = \mathbf{F}(s) = \int_0^{\infty} f(t)e^{-st} dt$$

The unit impulse function

$$\delta(t - t_0) = 0 \quad t \neq t_0$$

and

$$\int_{t_0-\varepsilon}^{t_0+\varepsilon} \delta(t - t_0) dt = 1 \quad \varepsilon > 0$$

Sampling property of the unit impulse function

$$\int_{t_1}^{t_2} f(t)\delta(t - t_0) dt = \begin{cases} f(t_0) & t_1 < t_0 < t_2 \\ 0 & t_0 < t_1, t_0 > t_2 \end{cases}$$

The initial-value theorem

$$\lim_{t \rightarrow 0^+} f(t) = \lim_{s \rightarrow \infty} s\mathbf{F}(s)$$

The final-value theorem

$$\lim_{t \rightarrow \infty} f(t) = \lim_{s \rightarrow 0} s\mathbf{F}(s)$$

Some properties of Laplace transform

Property Number	$f(t)$	$\mathbf{F}(s)$
1.	$Af(t)$	$A\mathbf{F}(s)$
2.	$f_1(t) \pm f_2(t)$	$\mathbf{F}_1(s) \pm \mathbf{F}_2(s)$
3.	$f(at)$	$\frac{1}{a}\mathbf{F}\left(\frac{s}{a}\right), a > 0$
4.	$f(t - t_0)u(t - t_0), t_0 \geq 0$	$e^{-t_0s}\mathbf{F}(s)$
5.	$f(t)u(t - t_0)$	$e^{-t_0s}\mathcal{L}[f(t + t_0)]$
6.	$e^{-at}f(t)$	$\mathbf{F}(s + a)$
7.	$\frac{d^n f(t)}{dt^n}$	$s^n\mathbf{F}(s) - s^{n-1}f(0) - s^{n-2}f'(0) \cdots s^0 f^{(n-1)}(0)$
8.	$tf(t)$	$-\frac{d\mathbf{F}(s)}{ds}$
9.	$\frac{f(t)}{t}$	$\int_s^{\infty} \mathbf{F}(\lambda) d\lambda$
10.	$\int_0^t f(\lambda) d\lambda$	$\frac{1}{s}\mathbf{F}(s)$
11.	$\int_0^t f_1(\lambda)f_2(t - \lambda) d\lambda$	$\mathbf{F}_1(s)\mathbf{F}_2(s)$

Laplace transforms of some special functions

$f(t)$	$\mathbf{F}(s)$
$\delta(t)$	1
$u(t)$	$\frac{1}{s}$
e^{-at}	$\frac{1}{s + a}$
t	$\frac{1}{s^2}$
$\frac{t^n}{n!}$	$\frac{1}{s^{n+1}}$
te^{-at}	$\frac{1}{(s + a)^2}$
$\frac{t^n e^{-at}}{n!}$	$\frac{1}{(s + a)^{n+1}}$
$\sin bt$	$\frac{b}{s^2 + b^2}$
$\cos bt$	$\frac{s}{s^2 + b^2}$
$e^{-at} \sin bt$	$\frac{b}{(s + a)^2 + b^2}$
$e^{-at} \cos bt$	$\frac{s + a}{(s + a)^2 + b^2}$

CHAPTER 14

The voltage-current relationship of a resistor in the s -domain

$$\mathbf{V}(s) = R\mathbf{I}(s)$$

The voltage-current relationship of a capacitor in the s -domain

$$\mathbf{V}(s) = \frac{\mathbf{I}(s)}{sC} + \frac{v(0)}{s}$$

$$\mathbf{I}(s) = sC\mathbf{V}(s) - Cv(0)$$

The voltage-current relationship of an inductor in the s -domain

$$\mathbf{V}(s) = sL\mathbf{I}(s) - Li(0)$$

$$\mathbf{I}(s) = \frac{\mathbf{V}(s)}{sL} + \frac{i(0)}{s}$$

Transfer or network function

$$\frac{\mathbf{Y}_o(s)}{\mathbf{X}_i(s)} = \mathbf{H}(s)$$

CHAPTER 15

Trigonometric Fourier series of a periodic function $f(t)$

$$\begin{aligned} f(t) &= a_0 + \sum_{n=1}^{\infty} D_n \cos(n\omega_0 t + \theta_n) \\ &= a_0 + \sum_{n=1}^{\infty} a_n \cos n\omega_0 t + b_n \sin n\omega_0 t \end{aligned}$$

where

$$a_n = \frac{2}{T_0} \int_{t_1}^{t_1+T_0} f(t) \cos n\omega_0 t \, dt$$

$$b_n = \frac{2}{T_0} \int_{t_1}^{t_1+T_0} f(t) \sin n\omega_0 t \, dt$$

and

$$D_n \angle \theta_n = a_n - jb_n$$

Exponential Fourier series of a periodic function $f(t)$

$$f(t) = \sum_{n=-\infty}^{\infty} \mathbf{c}_n e^{jn\omega_0 t}$$

where

$$\mathbf{c}_n = \frac{1}{T_0} \int_{t_1}^{t_1+T_0} f(t) e^{-jn\omega_0 t} \, dt$$

Relationships between various Fourier series coefficients

$$D_n \angle \theta_n = 2\mathbf{c}_n = a_n - jb_n$$

Fourier transform pair

$$\mathbf{F}(\omega) = \mathcal{F}[f(t)] = \int_{-\infty}^{\infty} f(t) e^{-j\omega t} \, dt$$

$$f(t) = \mathcal{F}^{-1}[\mathbf{F}(\omega)] = \frac{1}{2\pi} \int_{-\infty}^{\infty} \mathbf{F}(\omega) e^{j\omega t} \, d\omega$$

Fourier transform of some special functions

$f(t)$	$\mathbf{F}(\omega)$
$\delta(t - a)$	$e^{-j\omega a}$
A	$2\pi A\delta(\omega)$
$e^{j\omega_0 t}$	$2\pi\delta(\omega - \omega_0)$
$\cos \omega_0 t$	$\pi\delta(\omega - \omega_0) + \pi\delta(\omega + \omega_0)$
$\sin \omega_0 t$	$j\pi\delta(\omega + \omega_0) - j\pi\delta(\omega - \omega_0)$
$e^{-at}u(t), a > 0$	$\frac{1}{a + j\omega}$
$e^{-\alpha t }, a > 0$	$\frac{2a}{a^2 + \omega^2}$
$e^{-at} \cos \omega_0 t u(t), a > 0$	$\frac{j\omega + a}{(j\omega + a)^2 + \omega_0^2}$
$e^{-at} \sin \omega_0 t u(t), a > 0$	$\frac{\omega_0}{(j\omega + a)^2 + \omega_0^2}$

Some properties of Fourier transform

$f(t)$	$F(\omega)$	Property
$Af(t)$	$AF(\omega)$	Linearity
$f_1(t) \pm f_2(t)$	$F_1(\omega) \pm F_2(\omega)$	
$f(at)$	$\frac{1}{a} F\left(\frac{\omega}{a}\right), a > 0$	Time-scaling
$f(t - t_0)$	$e^{-j\omega t_0} F(\omega)$	Time-shifting
$e^{j\omega_0 t} f(t)$	$F(\omega - \omega_0)$	Modulation
$\frac{d^n f(t)}{dt^n}$	$(j\omega)^n F(\omega)$	
$t^n f(t)$	$(j)^n \frac{d^n F(\omega)}{d\omega^n}$	Differentiation
$\int_{-\infty}^{\infty} f_1(x) f_2(t - x) dx$	$F_1(\omega) F_2(\omega)$	Convolution
$f_1(t) f_2(t)$	$\frac{1}{2\pi} \int_{-\infty}^{\infty} F_1(x) F_2(\omega - x) dx$	

Convolution property of the Fourier transform

$$\mathbf{V}_o(\omega) = \mathbf{H}(\omega) \mathbf{V}_i(\omega)$$

CHAPTER 16

Two-port network admittance equations

$$\begin{bmatrix} \mathbf{I}_1 \\ \mathbf{I}_2 \end{bmatrix} = \begin{bmatrix} \mathbf{y}_{11} & \mathbf{y}_{12} \\ \mathbf{y}_{21} & \mathbf{y}_{22} \end{bmatrix} \begin{bmatrix} \mathbf{V}_1 \\ \mathbf{V}_2 \end{bmatrix}$$

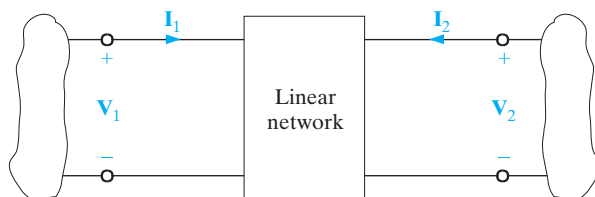

Two-port network impedance equations

$$\begin{bmatrix} \mathbf{V}_1 \\ \mathbf{V}_2 \end{bmatrix} = \begin{bmatrix} \mathbf{z}_{11} & \mathbf{z}_{12} \\ \mathbf{z}_{21} & \mathbf{z}_{22} \end{bmatrix} \begin{bmatrix} \mathbf{I}_1 \\ \mathbf{I}_2 \end{bmatrix}$$

Impedance parameters

$$\begin{aligned} \mathbf{z}_{11} &= \left. \frac{\mathbf{V}_1}{\mathbf{I}_1} \right|_{\mathbf{I}_2=0} & \mathbf{z}_{12} &= \left. \frac{\mathbf{V}_1}{\mathbf{I}_2} \right|_{\mathbf{I}_1=0} \\ \mathbf{z}_{21} &= \left. \frac{\mathbf{V}_2}{\mathbf{I}_1} \right|_{\mathbf{I}_2=0} & \mathbf{z}_{22} &= \left. \frac{\mathbf{V}_2}{\mathbf{I}_2} \right|_{\mathbf{I}_1=0} \end{aligned}$$

Admittance parameters

$$\begin{aligned} \mathbf{y}_{11} &= \left. \frac{\mathbf{I}_1}{\mathbf{V}_1} \right|_{\mathbf{V}_2=0} & \mathbf{y}_{12} &= \left. \frac{\mathbf{I}_1}{\mathbf{V}_2} \right|_{\mathbf{V}_1=0} \\ \mathbf{y}_{21} &= \left. \frac{\mathbf{I}_2}{\mathbf{V}_1} \right|_{\mathbf{V}_2=0} & \mathbf{y}_{22} &= \left. \frac{\mathbf{I}_2}{\mathbf{V}_2} \right|_{\mathbf{V}_1=0} \end{aligned}$$

Two-port network hybrid equations

$$\begin{bmatrix} \mathbf{V}_1 \\ \mathbf{I}_2 \end{bmatrix} = \begin{bmatrix} \mathbf{h}_{11} & \mathbf{h}_{12} \\ \mathbf{h}_{21} & \mathbf{h}_{22} \end{bmatrix} \begin{bmatrix} \mathbf{I}_1 \\ \mathbf{V}_2 \end{bmatrix}$$

Hybrid parameters

$$\begin{aligned} h_{11} &= \left. \frac{V_1}{I_1} \right|_{V_2=0} & h_{12} &= \left. \frac{V_1}{V_2} \right|_{I_1=0} \\ h_{21} &= \left. \frac{I_2}{I_1} \right|_{V_2=0} & h_{22} &= \left. \frac{I_2}{V_2} \right|_{I_1=0} \end{aligned}$$

Two-port network transmission equations

$$\begin{bmatrix} V_1 \\ I_1 \end{bmatrix} = \begin{bmatrix} A & B \\ C & D \end{bmatrix} \begin{bmatrix} V_2 \\ -I_2 \end{bmatrix}$$

Transmission parameters

$$\begin{aligned} A &= \left. \frac{V_1}{V_2} \right|_{I_2=0} \\ B &= \left. \frac{V_1}{-I_2} \right|_{V_2=0} \\ C &= \left. \frac{I_1}{V_2} \right|_{I_2=0} \\ D &= \left. \frac{I_1}{-I_2} \right|_{V_2=0} \end{aligned}$$

Two-port network parameter conversions

$$\begin{bmatrix} z_{11} & z_{12} \\ z_{21} & z_{22} \end{bmatrix} \begin{bmatrix} \frac{y_{22}}{\Delta_Y} & \frac{-y_{12}}{\Delta_Y} \\ \frac{-y_{21}}{\Delta_Y} & \frac{y_{11}}{\Delta_Y} \end{bmatrix} \begin{bmatrix} \frac{A}{C} & \frac{\Delta_T}{C} \\ \frac{1}{C} & \frac{D}{C} \end{bmatrix} \begin{bmatrix} \frac{\Delta_H}{h_{22}} & \frac{h_{12}}{h_{22}} \\ \frac{-h_{21}}{h_{22}} & \frac{1}{h_{22}} \end{bmatrix}$$

$$\begin{bmatrix} \frac{z_{22}}{\Delta_Z} & \frac{-z_{12}}{\Delta_Z} \\ \frac{-z_{21}}{\Delta_Z} & \frac{z_{11}}{\Delta_Z} \end{bmatrix} \begin{bmatrix} y_{11} & y_{12} \\ y_{21} & y_{22} \end{bmatrix} \begin{bmatrix} \frac{D}{B} & \frac{-\Delta_T}{B} \\ \frac{1}{B} & \frac{A}{B} \end{bmatrix} \begin{bmatrix} \frac{1}{h_{11}} & \frac{-h_{12}}{h_{11}} \\ \frac{h_{21}}{h_{11}} & \frac{\Delta_H}{h_{11}} \end{bmatrix}$$

$$\begin{bmatrix} \frac{z_{11}}{\Delta_Z} & \frac{\Delta_Z}{z_{21}} \\ \frac{1}{z_{21}} & \frac{z_{22}}{z_{21}} \end{bmatrix} \begin{bmatrix} \frac{-y_{22}}{y_{21}} & \frac{-1}{y_{21}} \\ \frac{y_{21}}{-\Delta_Y} & \frac{-y_{11}}{y_{21}} \end{bmatrix} \begin{bmatrix} A & B \\ C & D \end{bmatrix} \begin{bmatrix} \frac{-\Delta_H}{h_{21}} & \frac{-h_{11}}{h_{21}} \\ \frac{h_{21}}{-h_{22}} & \frac{-1}{h_{21}} \end{bmatrix}$$

$$\begin{bmatrix} \frac{\Delta_Z}{z_{22}} & \frac{z_{12}}{z_{22}} \\ \frac{-z_{21}}{z_{22}} & \frac{1}{z_{22}} \end{bmatrix} \begin{bmatrix} \frac{1}{y_{11}} & \frac{-y_{12}}{y_{11}} \\ \frac{y_{21}}{\Delta_Y} & \frac{\Delta_Y}{y_{11}} \end{bmatrix} \begin{bmatrix} \frac{B}{D} & \frac{\Delta_T}{D} \\ \frac{1}{D} & \frac{C}{D} \end{bmatrix} \begin{bmatrix} h_{11} & h_{12} \\ h_{21} & h_{22} \end{bmatrix}$$
